

Grammar reference

Pupil's Book

1 What's your name? **I'm** Suzy.
How old are you? **I'm** three.
I'm = I am

2 Who's he? **He's** Alex.
How old is she? **She's** seven.
he's = he is
she's = she is
that's = that is

3 Where's the ball?
It's **next to** the chair.
It isn't **under** the table.
Is your ball **in** your bag?
where's = where is
isn't = is not

4 **We're** happy.
We aren't ugly.
Are we small?
we're = we are
aren't = are not

5 They're long.
They **aren't** big.
Are they short?

6 I / you / we've **got** purple hair.
Have you **got** a small mouth?
Yes, I **have**. / No, I **haven't**.
I've got = I have got
haven't = have not

7 They've **got** big mouths.
They **haven't got** tails.
Have they **got** long legs?
they've got = they have got
haven't got = have not got

8 **She's got** your red trousers.
He hasn't got a white ball.
Has he/she **got** a train?
Yes, he/she **has**. /
No, he/she **hasn't**.
he's got = he has got
she's got = she has got
hasn't got = has not got

9 I **can** sing.
I **can't** play the guitar.
Can you ride a bike?
can't = cannot

10 What **are** you doing?
I'm flying.
Are you flying your
helicopter?

11 What's he/she doing?
He's/She's **listening** to music.
What **are** they doing?
They're **sitting** on the sofa.
Is he/she **listening** to music?
Yes, he/she **is**. /
No, he/she **isn't**.
what's = what is

12 I **like** cake.
I **don't like** chocolate.
Do you **like** snakes?
Yes, I **do**. / No, I **don't**.
don't = do not

Activity Book

AB94. ACTIVITY 1. Order the words.

Key: 1 What's your name? 2 How old are you?

AB94. ACTIVITY 2. Look and complete.

Key: 1 He's, He's, 2 She's, She's

AB94. ACTIVITY 3. Look and complete.

Key: 1 Is, is, 2 Is, isn't

AB94. ACTIVITY 4. Circle the sentences.

Key: We aren't sad. We're happy. Are we beautiful?

AB95. ACTIVITY 5. Look and complete.

Key: 1 It's, 2 They're

AB95. ACTIVITY 6. Order the words.

Key: 1 I've got a clean face. 2 You've got short hair.

AB95. ACTIVITY 7. Circle the sentences.

Key: They've got tails. They haven't got hair. Have they got legs?

AB95. ACTIVITY 8. Look and complete.

Key: 1 's got, 2 hasn't got

AB96. ACTIVITY 9. Order the words.

Key: 1 He can sing. 2 They can't swim. 3 Can you ride a bike?

AB96. ACTIVITY 10. Look and complete.

Key: 1 Are, am, 2 Are, not

AB96. ACTIVITY 11. Circle the sentences.

Key: What's he doing? He is having a bath. Is he reading?

AB96. ACTIVITY 12. Look and complete.

Key: 1 like, 2 don't like

Teaching notes for Photocopiables

Photocopiable 1 (Unit 1 page 5)

Hand out copies of Photocopiable 1 (page T97), one for each pupil.

Pupils cut the cards out (and colour them if there is time). Pupils work in pairs and take turns to play the game. Pupil A makes a line of five as in Activity Book page 5 Activity 3. Pupil B says the five names aloud and completes the sequence.

At the end of the game, each pupil puts their set of six cards into an envelope for use in another lesson.

Photocopiable 2 (Unit 2 page 13)

Hand out copies of Photocopiable 2 (page T98), one for each pupil.

Pupils colour in the puppets (about five minutes). Monitor the class carefully.

When all pupils are ready, hand out the scissors and the glue. Demonstrate cutting out one of the puppets. Pupils cut out their puppets.

Demonstrate how to curl back the tabs and glue one tab onto the other. Pupils glue the tabs in place and then play with their finger puppets (see page T13).

Photocopiable 3A (Unit 3 page 20)

Show the class a completed sentence wheel from Photocopiable 3A. Turn the wheels and make sentences, e.g. *The car is under the chair.*

Hand out copies of Photocopiable 3A (page T99), one for each pupil.

Pupils colour the pictures and cut out the three circles. Hand out the paper fasteners. Pupils clip the wheels together, with the largest wheel at the bottom and the smallest wheel on top.

Check pupils understand that the four cat pictures on the middle circle illustrate *on*, *in*, *next to* and *under*.

Practise by calling out sentences for pupils to make with their sentence wheels, e.g. *The train is under the toy box.* They line up their wheels accordingly. Pupils call out sentences too.

Pupils work in groups of four. They take turns to call out sentences for the others to make with their wheels. The first to make the sentence becomes the caller.

Photocopiable 3B (Unit 3 page 19)

Hand out copies of Photocopiable 3B (page T99), one for each pupil.

Pupils cut out the six cards.

Draw a 3 x 2 grid on the board. Number the squares 1–6. Pupils copy it into their notebooks. A card will need to fit in each square.

Turn away from the board. Use a pupil's grid and cards. Two pupils place six toy flashcards (35–40) in the squares on the board. Ask, e.g. *What's number 2?* Elicit a response, e.g. *(It's) a car.* Place the small car card in square 2 of the pupil's grid. Repeat for the other squares. Look and check if the position of the card pictures matches the flashcards.

Pupils play in pairs. They sit facing one another, hiding their grids so their partner can't see. Pupil A places the cards. Pupil B asks and then places his/her cards in the same squares. They look and check. They change roles and repeat.

Pupils put their cards in an envelope at the end of the game and write their name on the envelope. Collect the envelopes so the cards can be used in another lesson.

Photocopiable 4 (Unit 4 page 26)

Show pupils the dice you have already made and throw it. Pupils call out the word, e.g. *Young*. Check pupils understand that the dice illustrates *old*, *ugly*, *young*, *beautiful*, *happy* and *sad*.

Show pupils the game board. Elicit who they can see (*Stella and the Star family*). Say, e.g. *Her mother is beautiful*. Show thumbs up. Elicit other true sentences from the class.

Demonstrate the game. Explain that the coin will show how many squares to move and the dice will show which adjective to use. Toss a coin. Heads move one square, tails two squares. Use an eraser for a counter. Move to the square indicated by the coin. Then throw the dice and make a sentence about the person, using the adjective on the dice, e.g. *Her father is beautiful*. Show thumbs down to say that it isn't true. If pupils land on a square with a picture of a thumb, they don't make a sentence.

Divide the class into pairs. Hand out copies of Photocopiable 4 (page T100), one for each pair of pupils.

Pupils cut out the dice and the board. Show pupils how to glue the dice together.

Hand out a coin to each pair. Monitor pupils as they are working. The first player to reach the finish is the winner. Pairs who finish early can play again.

Collect the materials at the end of the game for use in another lesson.

Photocopiable 5 (Unit 5 page 35)

Make two groups. Hand out copies of Photocopiable 5 (page T101) part A to one group and part B to the other group.

Pupils work in pairs with the same pictures (A + A or B + B). They look at the pictures, find the animals and count them.

Make new pairs of pupils from different groups (A + B). They put their photocopies on the table and take turns to point and say, e.g. A: *Six dogs*. B: *Five dogs*. When there are differences, they circle them in pencil. Check with the class.

Key:

A: Six dogs B: Five dogs

A: One cat under the table B: Two cats on the table

A: Old horse B: Beautiful horse

A: Four mice B: One mouse

A: One fish B: Two fish

A: Eight birds B: Nine birds

Photocopiable 6 (Unit 6 page 41)

Show pupils your completed puppet. Say in a troll voice *Hi, my name's (name). I'm a troll. My eyes are (green), my hair is (green) and (red).*

Hold up a copy of Photocopiable 6 (page T102). Show pupils what to do (draw ears, mouth, teeth, colour the troll and stick on hair).

Hand out the photocopies (one for each pupil) and materials. Monitor pupils as they are working. When pupils are ready, hand out the scissors for pupils to cut out their trolls, and the lollypop sticks and the glue for them to make the puppets. Pupils name their trolls. Put an envelope on each pupil's desk.

Show your puppet to the class again. Introduce yourself as at the beginning. Encourage a pupil to reply in the same way, e.g. *Hi. My name's (name). I'm a troll. My eyes are (blue and red). My hair is (purple).* Repeat.

Pupils work in groups of four and introduce their trolls to their friends.

Photocopiable 7 (Unit 7 page 51)

Show pupils the dominoes you have made. Demonstrate how to play the game. Remind pupils to say the animal word when they make a match.

Make groups of three. Hand each group a copy of Photocopiable 7 (page T103) cut into three strips. Each pupil cuts a strip to make six dominoes.

They place the dominoes face down on the table. Each pupil takes four dominoes. The first

player places a domino face up on the table. The next player matches either the word or the picture, saying the word and placing their domino next to the previous one on the table. If he/she can't go, he/she picks up one of the spare dominoes and the next player has a go. Play continues until there are no spare dominoes left and one player has put down all their dominoes.

Remind pupils of the language for playing games, e.g. *It's your turn. Is it my turn?*

Groups place their cards in envelopes for use in another lesson.

Photocopiable 8 (Unit 8 page 61)

Show the class your set of cards. Elicit what they are, e.g. *Green socks, blue shoes.* Hand out a copy of Photocopiable 8 (page T104) to each pupil. Dictate the colours, e.g. *Colour the skirt red.* Choose different colours for each clothes item.

Pupils cut up the cards and write their name on the back of each one, so they can identify them later.

Mix four sets of cards together. Deal them to four pupils. Pupils ask each other for cards to collect sets of four the same, e.g. *Have you got blue shoes?* They take it in turns to ask, going clockwise around the circle. They can ask whoever they choose in their group. When they get a set, they put it down on the table. They continue until all the sets are found, or the time is up.

Review language for playing games, e.g. *It's my/your turn.* Make groups of four. Pupils play the game.

At the end, pupils take back their own cards and put them in an envelope for use in another lesson.

Photocopiable 9a (Unit 9 page 65)

Show your set of cards. Hold up the card with the word swim on it and the card with a picture of Marie playing the guitar. Say *Is this a match?* Pupils respond *No.* Show the other picture cards for pupils to choose the match (swim picture).

Hand out a copy of Photocopiable 9a (page T105) to each pupil. They cut out the 12 cards and put their initial in the corner of each card. (They don't write on the back.)

Review language for playing games. Make pairs. Pairs put one set of 12 cards face down on the desk and mix them up. Pupils take turns to turn over two cards. They say or read the action on each card. If they are the same (picture and phrase), the pupil takes the pair. If not, the pupil turns them face down again. Play continues until all the cards are matched. The winner is the pupil with the most cards.

Pupils put their cards in envelopes for use in another lesson.

Photocopiable 9b (Unit 9 page 68)

Quickly review the actions from Unit 9, using the flashcards. Display them on the board.

Hand out copies of Photocopiable 9b (page T106). Demonstrate the activity. Point to the picture of swim and ask a pupil, e.g. *Can you swim?* The pupil answers *Yes, I can / No, I can't.* Put a tick or a cross next to the swim picture. Prompt the short answer each time. Pupils respond in chorus.

Make pairs or small groups. Pupils take turns to ask and answer. They write pupils' names at the top of the chart. They put a tick or a cross below the names for each action. Check in open pairs around the class.

Note: Instructions for this activity are also on page T68.

Photocopiable 10 (Unit 10 page 71)

Show pupils the board game you have made. Make pairs. Hand out one copy of Photocopiable 10 (page T107) part B and two copies of part A to each pair. They colour the small circles (A) in colours that they know in English, cut them out and stick them in the correct places on the board (B).

Demonstrate the game. Pupils put their counters on Start. They spin a pencil and, when it lands, the person that the pencil is pointing to starts. The first player tosses the coin: heads they move one space, tails two. The pupil moves the counter to the space and says what it is, e.g. *A green helicopter.* If pupils make a mistake, e.g. say the wrong colour or the wrong ride, they miss a turn.

Remind pupils of language for playing games, e.g. *It's my turn.* Also teach them *That's wrong! Miss a turn.*

Pupils take turns to play. The player who gets to *Finish* first is the winner. Collect the game boards for use in another lesson.

Photocopiable 11 (Unit 11 page 78)

Show pupils your copy of Photocopiable 11 (page T108). Hand out a copy of parts A and B to each pair of pupils. They colour the cards in B and then cut them out. They place the house in A on the desk between them.

Pupils take turns to give instructions for six of the cards, e.g. Pupil A says *Put the trousers in the kitchen.* Pupil B puts the trousers card in the kitchen. Monitor pupils as they are working. Encourage them to use different cards each time.

Collect the materials at the end of the game. Pupils put them in envelopes with their names on for use in another lesson.

Photocopiable 12 (Unit 12 page 87)

Show pupils your completed food market with different coloured foods (you only need two or three for each colour).

Pupils work in groups of four. Hand out a copy of Photocopiable 12 (page T109) to each group. They colour the headings in the correct colours.

Hand out supermarket adverts/leaflets to groups. They find pictures of coloured foods, cut them out and stick them on their photocopies. They can also draw different coloured foods they know. Elicit the known foods and provide other food words when appropriate.

Groups show their food markets. Ask which colour food they have most of.

Photocopiable 1



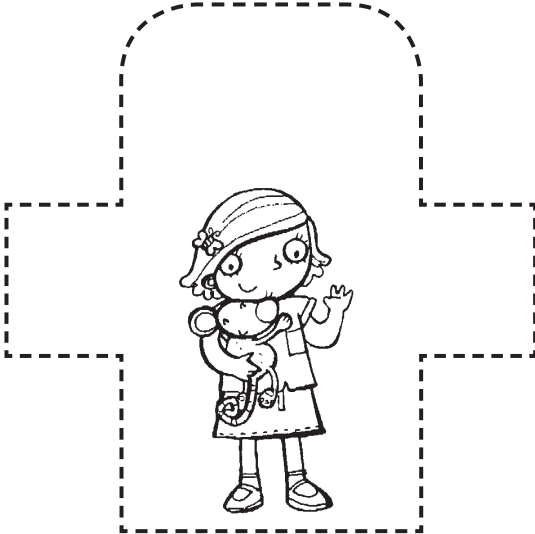
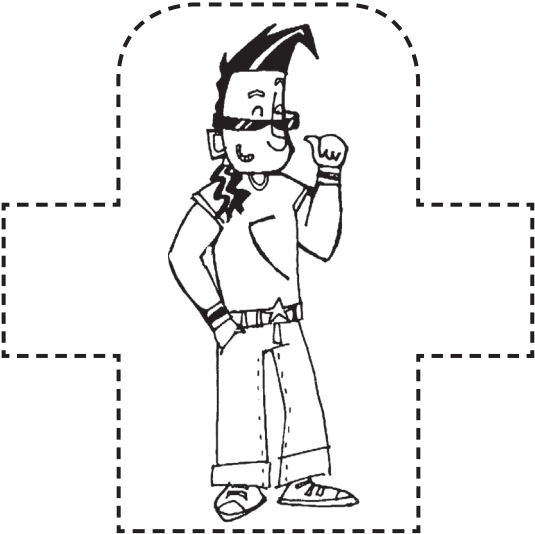
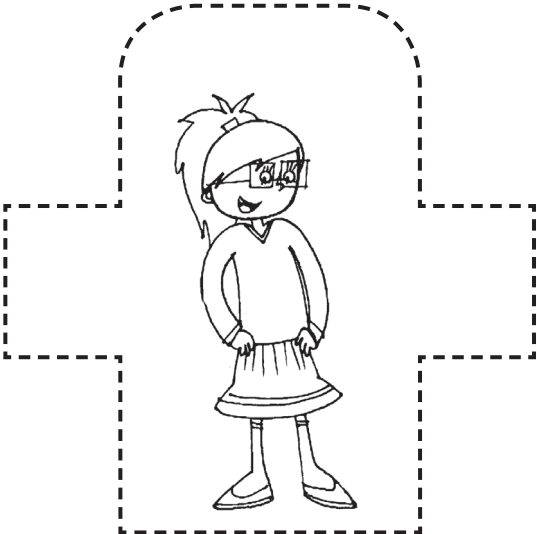
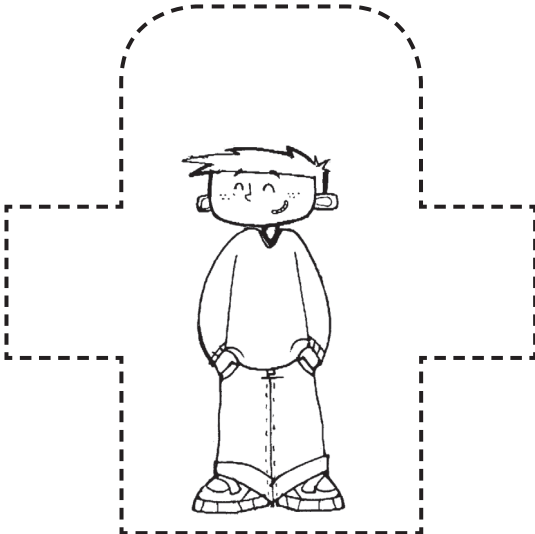
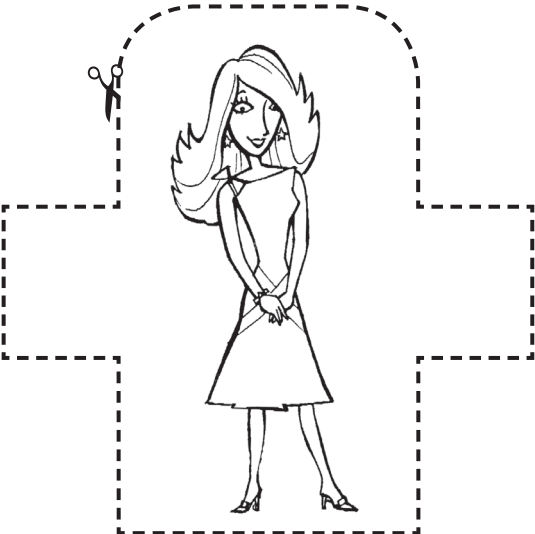

A

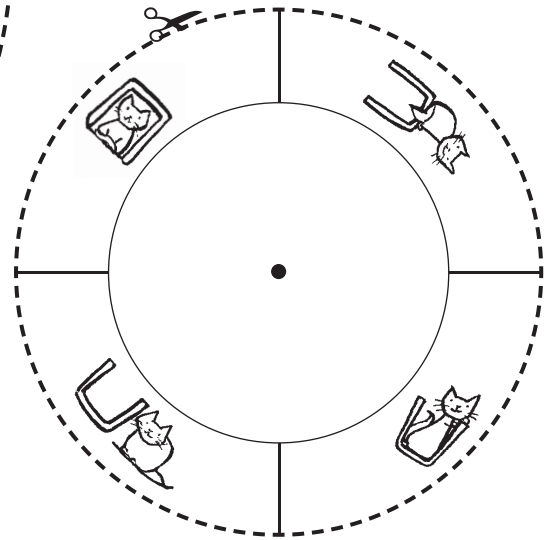
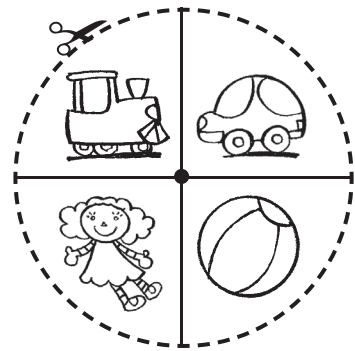
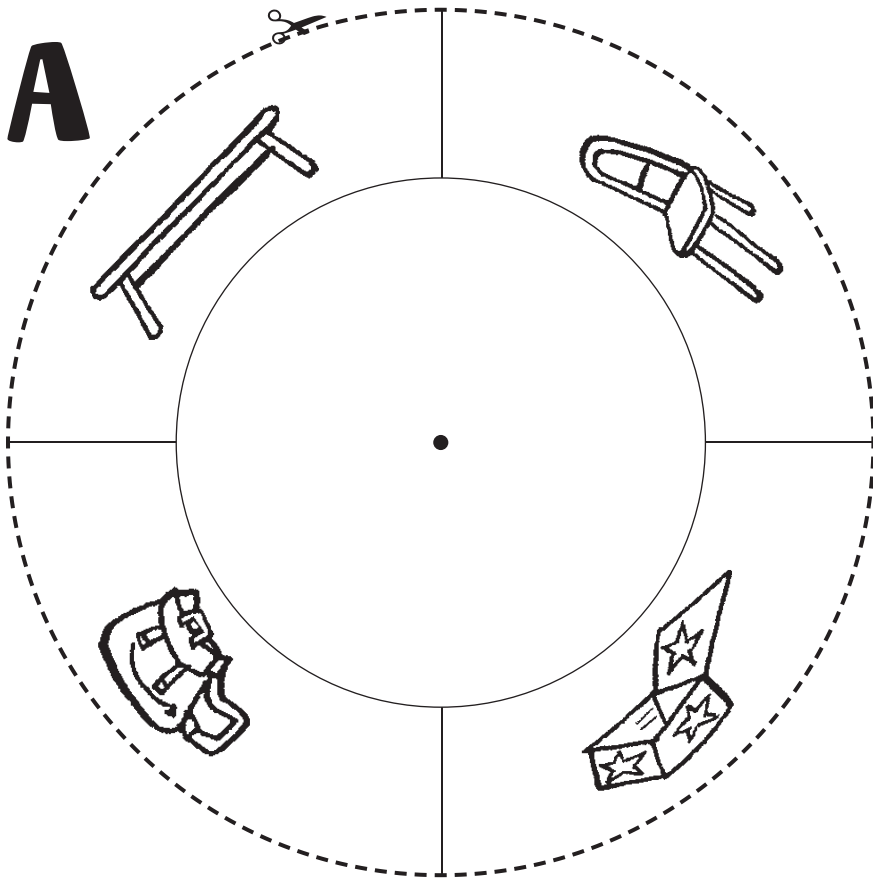

B

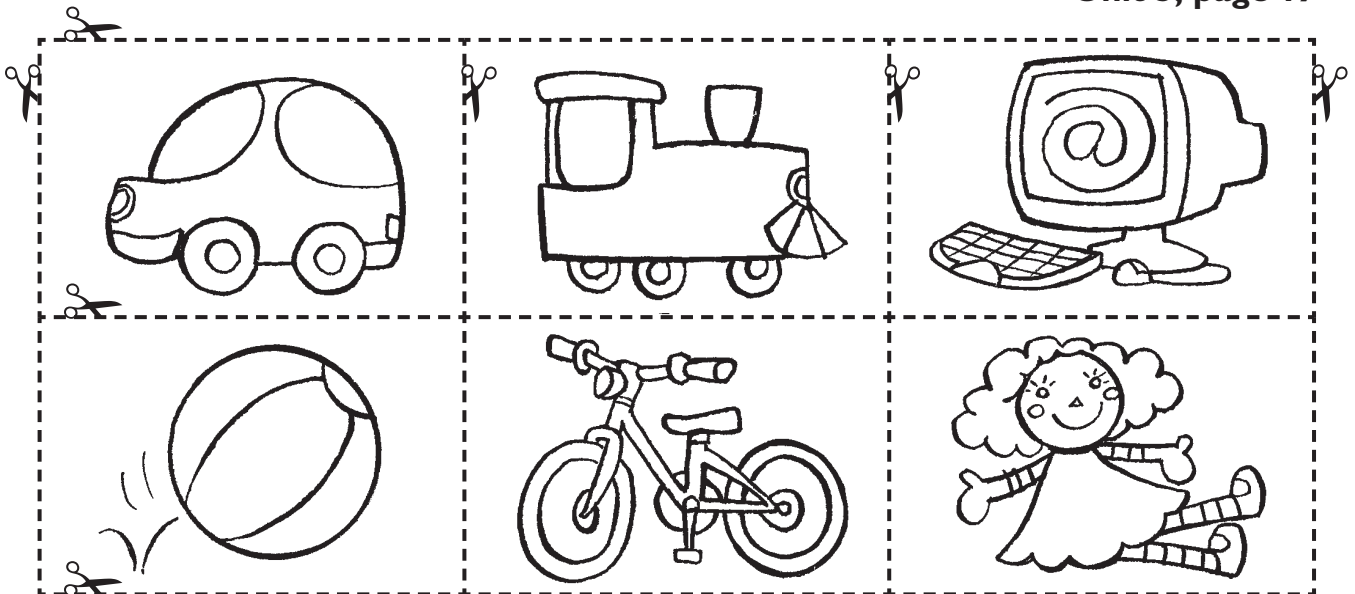

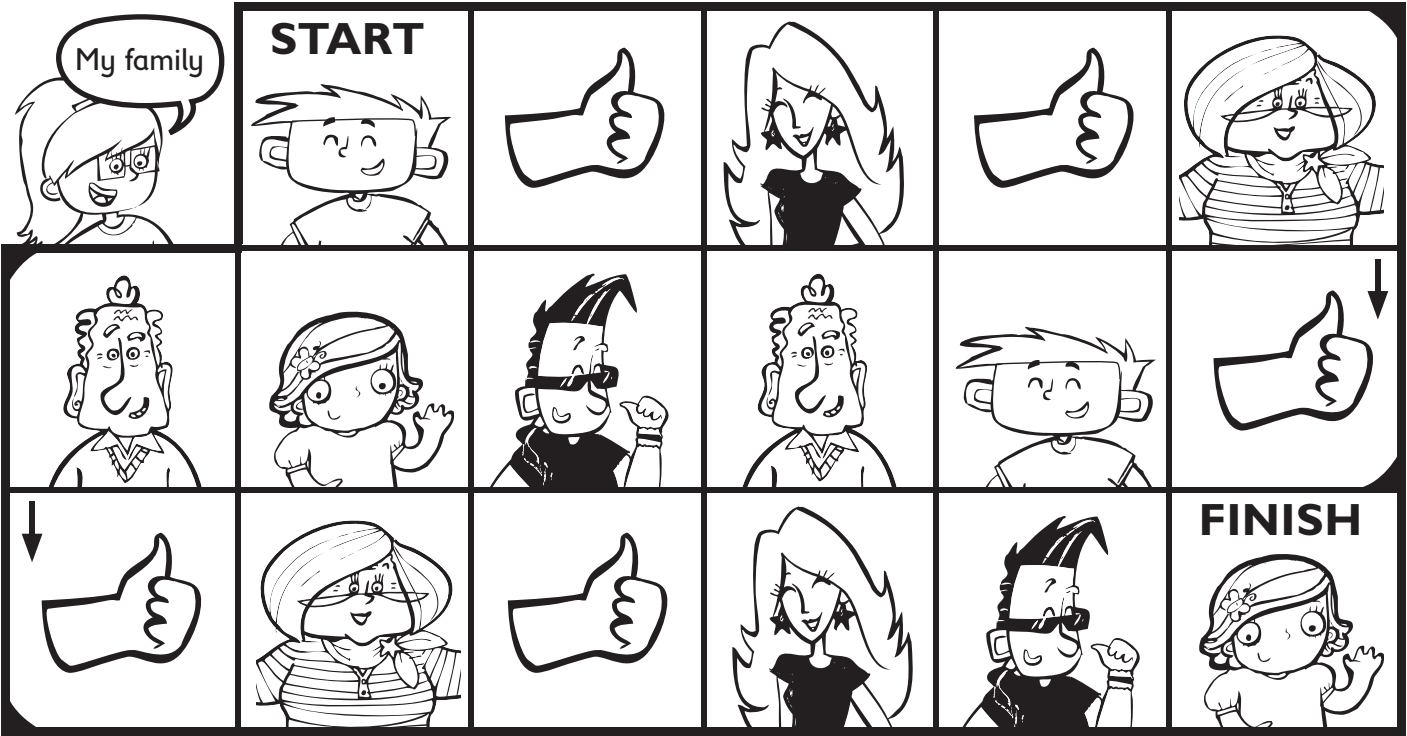
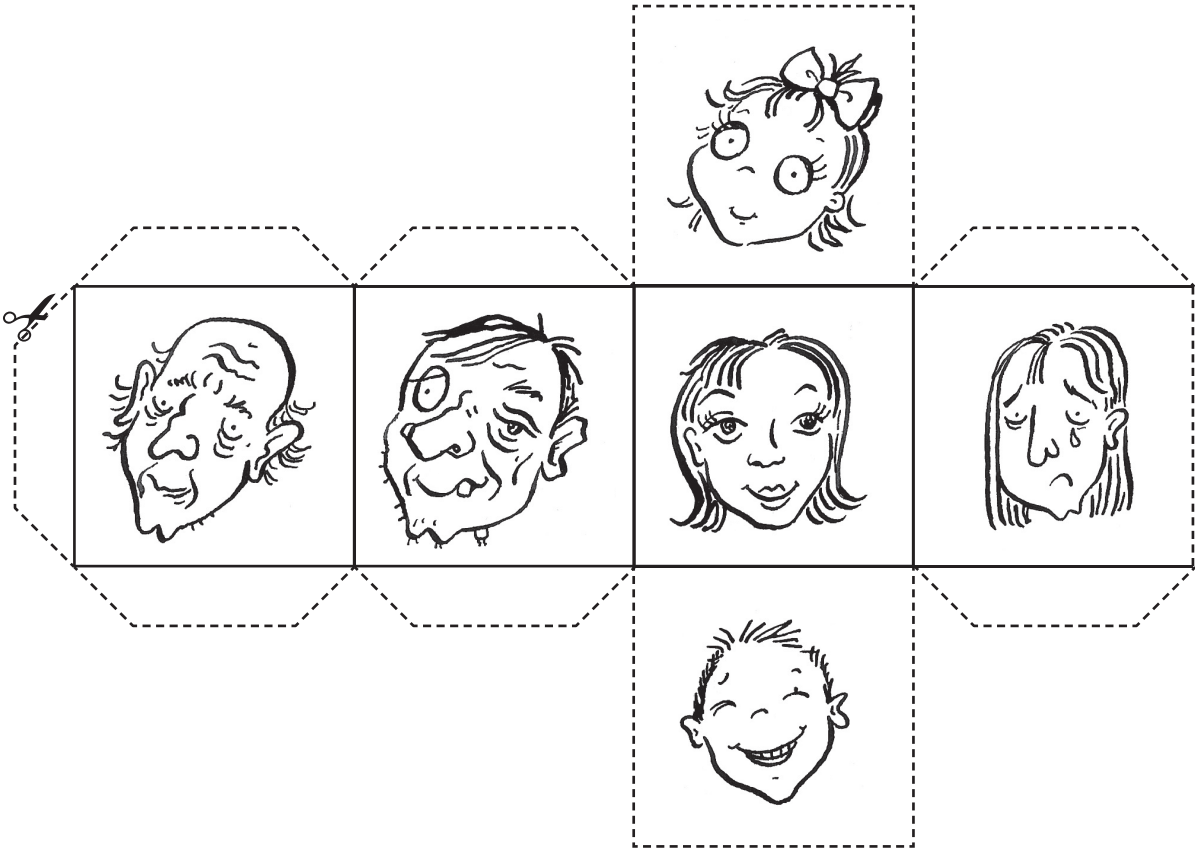

A





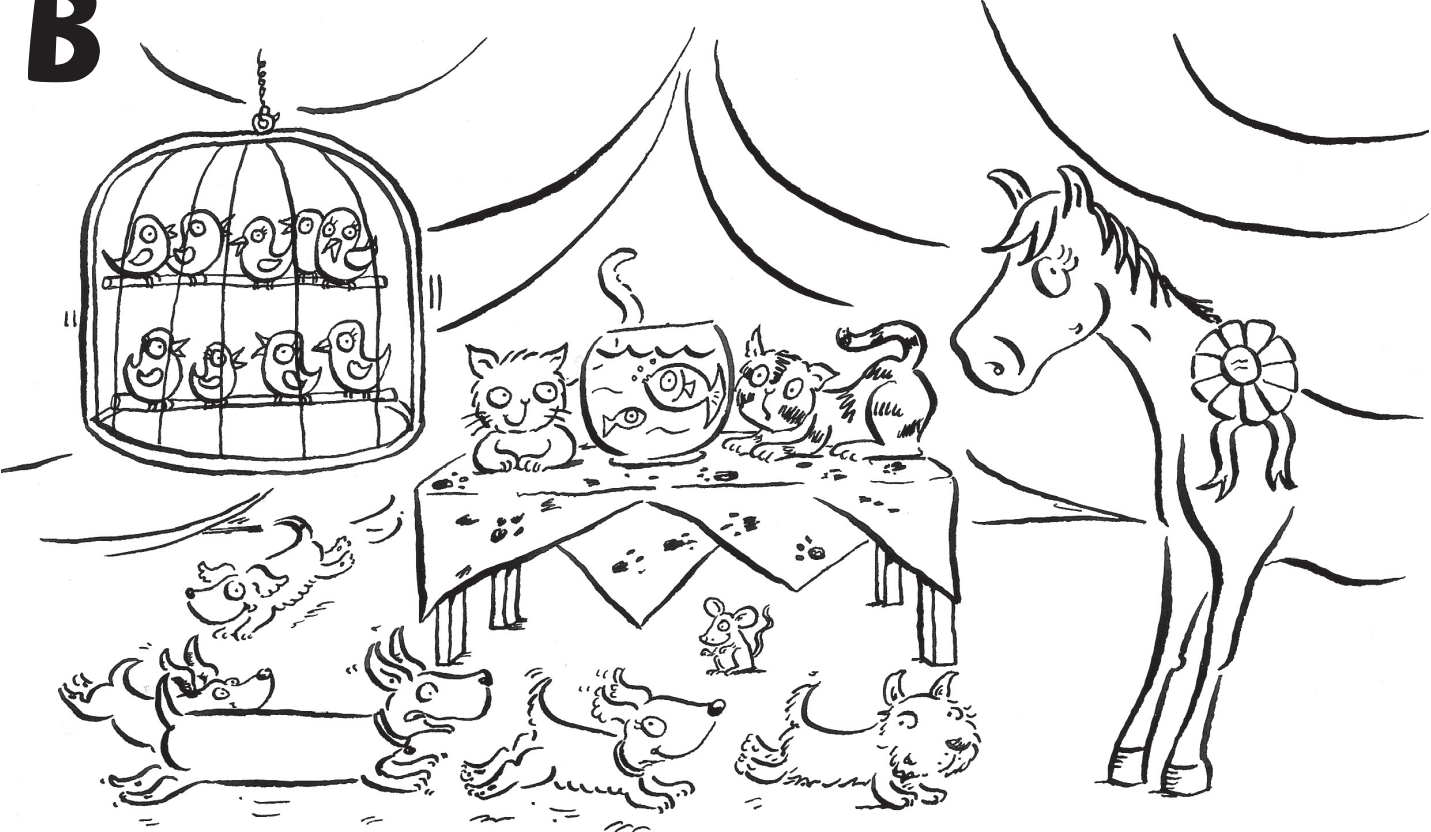

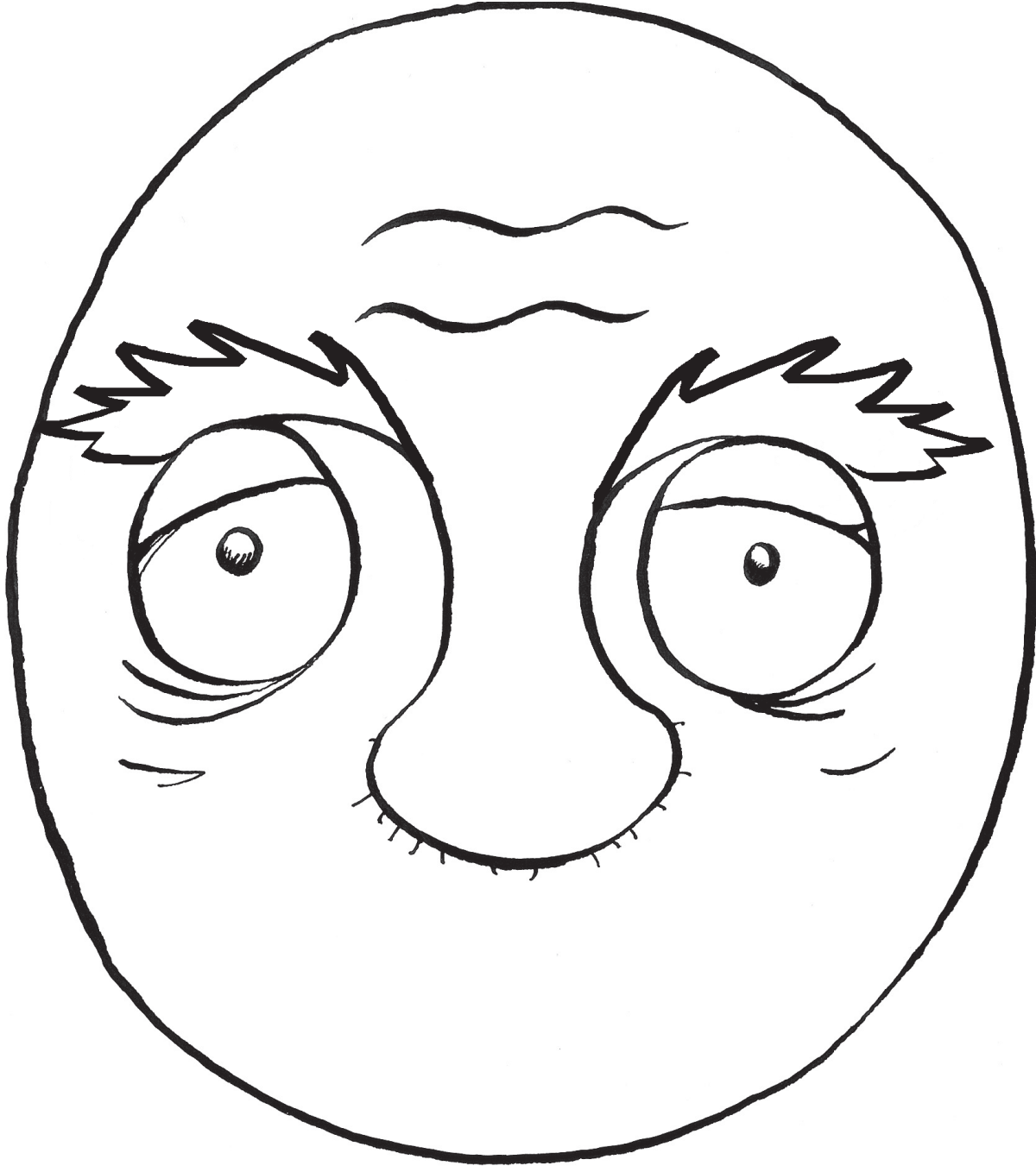





B

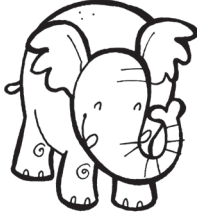

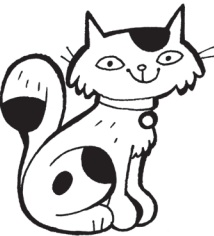

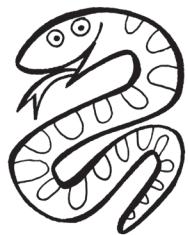



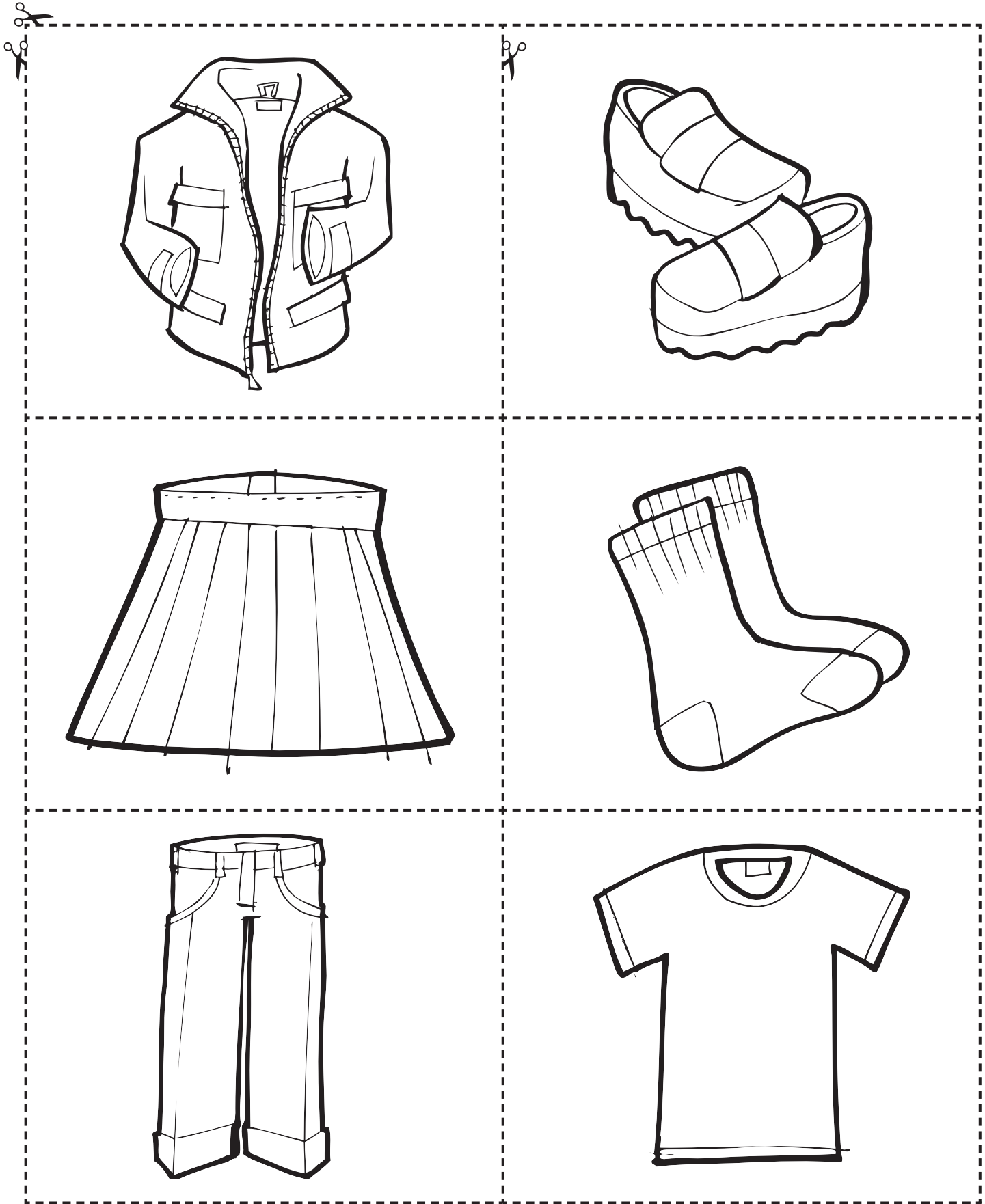

Photocopiable 7

	giraffe		elephant		monkey
	hippo		tiger		snake
	crocodile		cat		horse
	giraffe		elephant		monkey
	hippo		tiger		snake
	crocodile		cat		horse







Photocopiable 8



Photocopiable 9a

		
		
play football	play basketball	play tennis
play the guitar	swim	ride a bike

Photocopiable 9b

Name					
					
					
					
					
					
					

Photocopiable 10

A

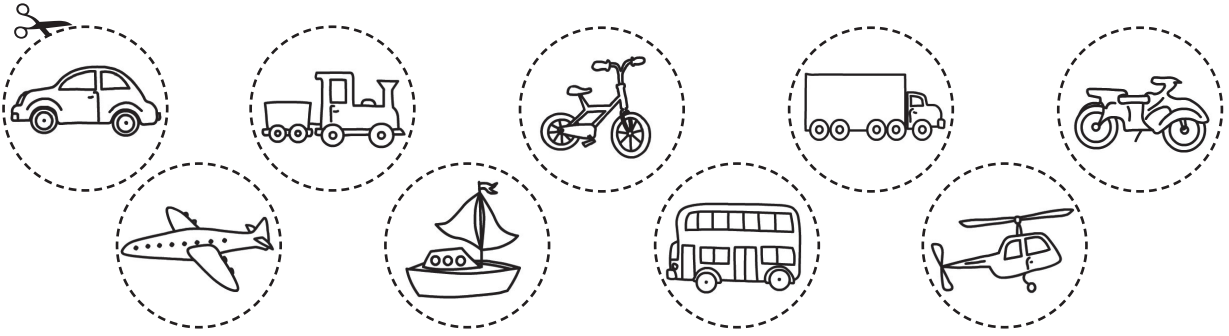

B

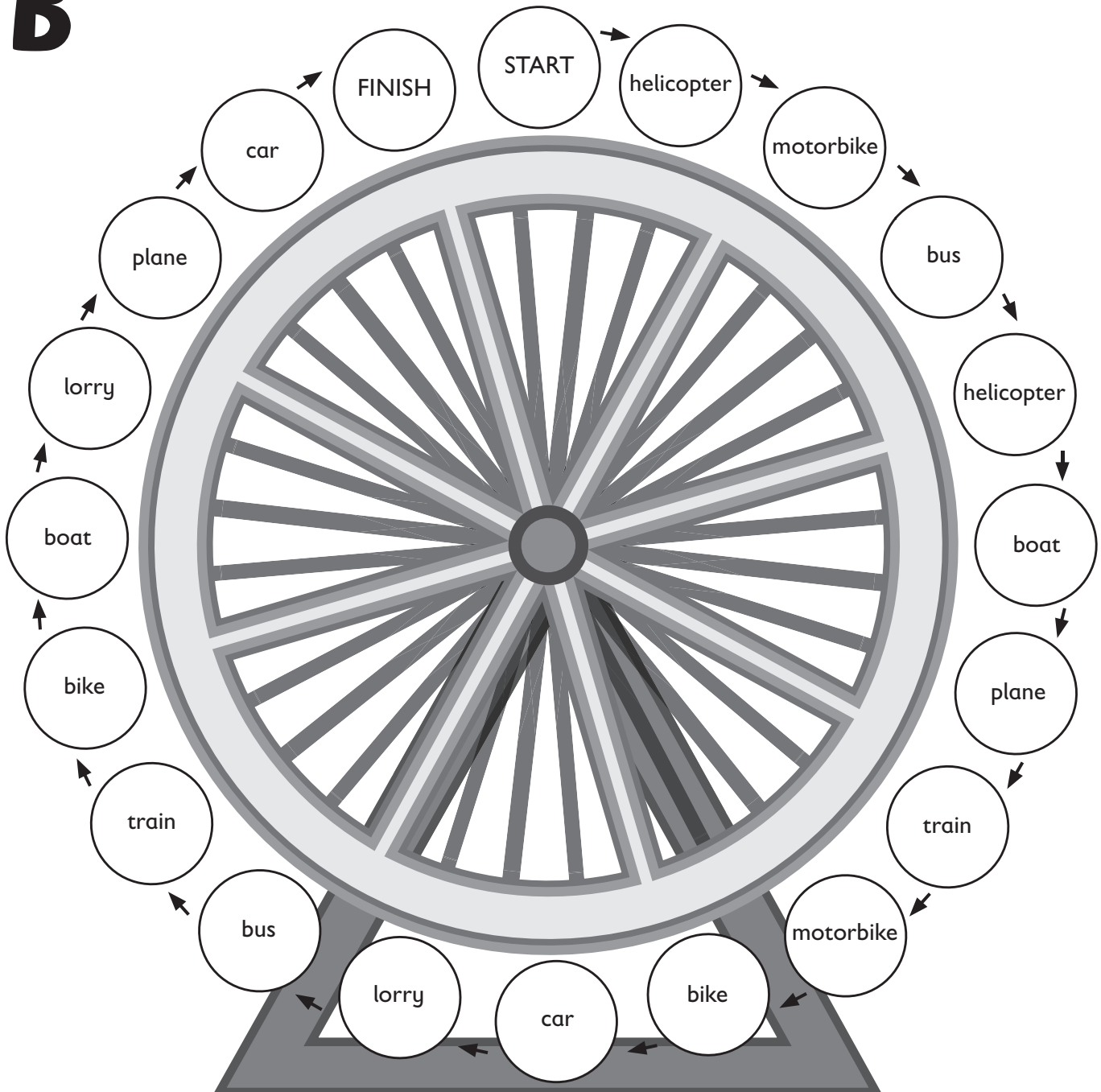

A



B

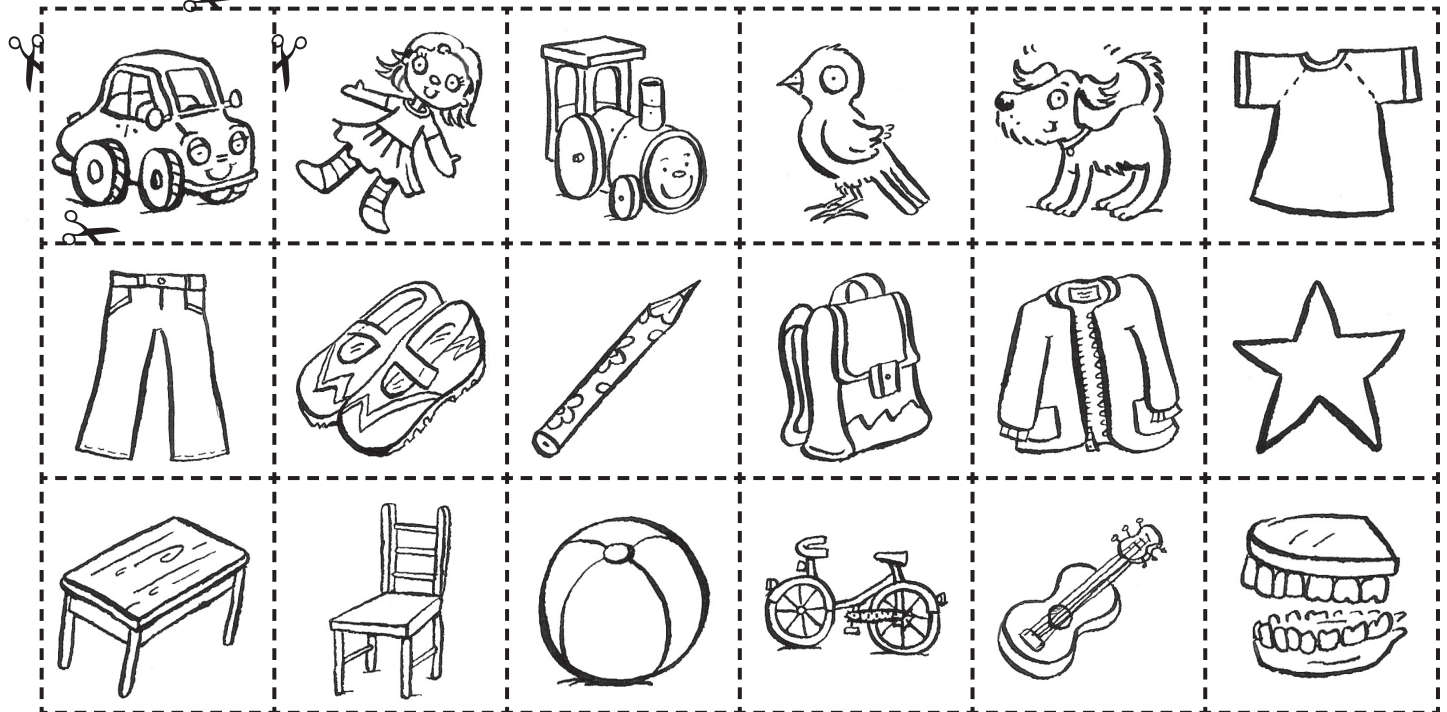



Extra activities

Unit 1

Page 4

- **Extra activity 1: Guessing game**

Place the character flashcards (1–5 + 8) on the desk. Make sure pupils can't see. Take one flashcard and hold it facing you. Say *Who's this?* Pupils take turns to guess. Show them when they guess correctly. Repeat.

- **Extra activity 2: Role play**

Five pupils come to the front. Hand each pupil a character flashcard. Pupils show their flashcards to the class in turn and say, e.g. *Hello. I'm Suzy Star.* Repeat.

Page 5

- **Extra activity 1: Air drawing game**

Say *One*. Draw a 1 in the air with your finger. Repeat with the other numbers up to *ten* in sequence. Pupils draw the number in the air. Continue, but say the numbers at random. Pupils work in pairs. They take it in turns to say a number for their partner to draw in the air.

- **Extra activity 2: Pointing game**

Display the ten cards each with a different number of dots between one and ten around the room. Say numbers at random. Pupils point to the correct card. Say the numbers quickly and then quietly. Invite pupils in turn to call the numbers.

Page 6

- **Extra activity 1: Back drawing**

Invite a pupil to come to the front and face the board. Stand so that the class can see you. Trace a large 3 with your finger on the pupil's back. (Alternatively, if you prefer, you can trace numbers on the desk for this activity.) Repeat the drawing. Elicit the number from the pupil. Check with the class. Repeat with another pupil and another number. Pupils work in pairs and play the game. Remind them to do it slowly and to make the number really big.

- **Extra activity 2: Matching the cards**

Display the ten dot cards on the board at random. Write the wrong number between 1 and 10 under each card, e.g. under the card with six dots, write 2. Invite pupils in turn to come and swap two cards so that one set of dots matches the number underneath. Repeat until all the cards and the numbers match.

Page 7

- **Extra activity 1: Make a rainbow**

Give each pupil a paper plate and seven strips of tissue paper, each of a different colour. Pupils stick the tissue onto the plate to make a rainbow.

Pupils get into groups of four and say the colour sequence of their rainbow.

- **Extra activity 2: Memory game**

Display five of the colour flashcards (from 20–26) on the board. Elicit from pupils which colours are missing. Pupils say, e.g. *Red. Green.* Take the flashcards off the board. Repeat with different colours missing each time.

Page 8

- **Extra activity 1: Board slap**

Two teams line up facing the board. Stick the colour flashcards (20–26) on the board. Hand a ruler to the first pupil in each team. Say a colour, e.g. *Blue.* The two pupils run to touch the colour. The first to hit it with the ruler wins a point for their team. The two pupils go to the back of the lines. Hand the rulers to the two pupils at the front. Continue until all the pupils have had a turn. The team with the most points is the winner.

- **Extra activity 2: Happy families**

Pupils work in groups of four. They take the six character cards from Photocopiable 1 (see pages T95 and T97) out of the envelopes and place them face down on the desk. (There are 24 cards altogether.) Each pupil takes six cards in turn. Number the pupils: 1, 2, 3, 4. Number 1 starts. Pupil 1 asks Pupil 2, 3 or 4 (he/she can choose) for a card he/she wants, e.g. *Maskman, please.* If the pupil has it, he/she gives it to Pupil 1. Then it is Pupil 2's turn to ask. The game continues. When one pupil has four cards the same, he/she puts them down on the desk and is the winner. Pupils put their cards in their envelopes.

Page 9

- **Extra activity 1: Counting game**

Slowly look through Unit 1 of the book. Count aloud new vocabulary items that pupils have learnt, e.g. *1 snake, 2 stars, 3 toys.* Pupils look at their books. Say a number. Pupils try to remember what the word is. Repeat.

- **Extra activity 2: Pick a number**

Show pupils the envelope containing numbers between 1 and 10 on small pieces of paper. Say to a pupil *Come and pick a number.* The pupil comes and takes a piece of paper. He/She reads out the number and then goes back to his/her chair. Repeat with the other pupils. Say, e.g. *Threes stand up, please. Nines pick up a red crayon, please.*

Unit 2

Page 10

- **Extra activity 1: Colour bingo**

Review the seven colours. Pupils draw a small 2 x 2 grid in their notebooks. They colour each square a different colour. Call out the colours one by one. When a pupil hears a colour, he/she puts a cross through that square. The first pupil to cross out all four squares is the winner and calls the colours in the next round. Repeat.

- **Extra activity 2: Action game**

Collect ten classroom objects from pupils, e.g. a red pencil, a green eraser. Pupils stand behind their chairs. Hold up, e.g. a blue pen, and say *It's a blue pen.* Hold up, e.g. four pencils and say *Five pencils.* Pupils stand still for true sentences and jump in the air for false ones. Pupils who do the wrong action sit on their chairs. Continue until you have a group of winners.

Page 11

- **Extra activity 1: True or false?**

Pupils work in pairs. They take turns to make and correct other sentences about the pictures in Pupil's Book page 11 Activity 4. Some of the sentences can be true this time.

- **Extra activity 2: Colour and say**

Pupils colour their own pictures in Activity Book page 11 Activity 3. They take turns to tell each other about the colour of the objects, e.g. *The book is red.*

Page 12

- **Extra activity 1: Chant**

Teach the following chant. Divide the class into different groups (e.g. boy/girl) and do the chant again.

How old are you?

How old is she?

I'm two, I'm two.

She's three, like me.

How old are you?

How old is she?

I'm two!

She's three!

How old is he?

He's three. He's three.

How old is he?

He's three!

● Extra activity 2: Monster fun

Pupils draw and colour two pictures, one of a boy monster and one of a girl monster. They write the ages (between 1 and 10) on the back. Pupils work in groups of four. They put their pictures, monster side up, on the desks. They take it in turns to point to a picture by one of the other pupils and ask *Is she* (age)? They have one guess each time. When pupils guess correctly, they take the monster picture. The pupil in each group with the most monsters is the winner. Pupils take back their own monsters and stick them in their notebooks. They write the age underneath.

Page 13

● Extra activity 1: Meet and greet!

You will need space for this activity.

Personalise the song from CD1, 27. Go up to a pupil. Say (Pupil's name x 2), *how are you?* The pupil replies *I'm fine, thank you. I'm fine, thank you. How are you?*

Repeat with different pupils.

Pupils stand up and find a space. Play the CD of lively music.

Pupils move around. Pause the CD. Pupils make pairs and say: Pupil A: (Pupil's name x 2), *how are you?* Pupil B: *I'm fine, thank you. I'm fine, thank you. How are you?* Start the music again. Repeat.

● Extra activity 2: Match the words

You will need a stopwatch or timer and the classroom item flashcards. Make teams of six pupils. Stick the classroom item flashcards on one side of the board, in random order. Write the six words for the items on the other side (*table, book, chair, eraser, pen, pencil*), not in the same order as the pictures and with plenty of space between the words.

Demonstrate the game. Say *Look, read and match*. Point to the first word on the board and elicit the name (e.g. *table*). Ask pupils to point to the correct flashcard on the board. Move the flashcard next to the word label.

Say *Now let's play*. Call one team to the front of the class. They stand in a line. Call the first pupil from the team forward and say *Look, read and match*. Start the stopwatch or timer. The first pupil chooses one of the words and matches the flashcard. The other team members can help. The next pupil chooses a different word and matches the card, and so on, until all the words and cards are matched. Stop the stopwatch when the team have finished and check with the class that the words and cards match. Write the team's time down.

Clean the board and set the game up again. Repeat with the next team of six pupils. Continue until each team has had a turn and then compare times to see which team was the fastest.

Page 14

● Extra activity 1: Memory game

Pupils use Pupil's Book page 14 Activity 10 for this game. They work in pairs. Pupil A closes his/her book. Pupil B asks *Who's number 1?* Pupil A responds, e.g. *Mr Star*. Then they swap roles.

● Extra activity 2: Colouring game

Give each pupil a blank piece of paper and read out the following instructions, using gesture to help show meaning and pausing after each instruction for pupils to draw:

Draw a table. Now draw these things on the table. Draw a book. Draw a pencil and an eraser. Draw a bag.

Say *Colour your picture*. Tell the pupils to choose a different colour for each item and to keep their picture hidden.

Pupils work in pairs. Pupil A asks about the colours of the objects in Pupil B's picture, e.g. *What colour is the book?* Pupil B responds without showing Pupil A the picture (e.g. *It's red*). After he/she has asked about all the items, Pupil A tries to remember all the colours of the objects in his/her partner's picture (*The book is red, etc.*). Pupil B checks and helps as necessary and then shows Pupil A the picture. Then pupils swap roles.

Page 15

● Extra activity 1: Matching game

Pupils play a game with the six picture dictionary stickers for Unit 2. They don't remove the backing sheets. Pupils work in groups of four. They place the 24 stickers face down on the tables in front of them. They take it in turns to turn over two stickers. They say what is on the pictures. If they match, the pupil takes them. If not, the pupil turns them face down again. Play continues until all the stickers have been matched.

● Extra activity 2: Chant

Teach the following chant line by line. Divide the class into different groups for different lines: quiet, loud, stand up, sit down and so on. Pupils can name other things in the room if they know them and create other verses.

School, school, we're in school.

Desk, chair, pencil,

We're in school.

School, school, I like school.

Book, pen, eraser,

I LIKE SCHOOL!

Page 16

● Extra activity: Classroom object sums

Hand out pieces of paper for pupils to draw their own pictures of groups of classroom objects (one to ten objects) as in Pupil's Book Activity 1. Have various pupils at the front to draw their sum on the board and ask their question. Pupils put their hands up to answer.

Page 17

● Extra activity: Greetings dialogues

Give pupils the photos cut from magazines of children with the information on the reverse. Tell the pupils to keep the pictures and information secret. Pupils move around the classroom greeting each other as if they were the people on the pictures. They ask and answer questions to gain information about one another. Tell them to think about the 'values' and make sure they are using friendly language such as *Let's play* and *How are you?* Choose pairs to act out their dialogues to the class.

Unit 3

Page 18

● Extra activity 1: Disappearing flashcards

Display the toy flashcards (35–40) face up around the room. Elicit each one in turn and then turn each flashcard to face the wall. Point to each one in turn again. Pupils say them from memory. Continue. Turn one flashcard face up each time you elicit a word, until all the flashcards are face up again.

● Extra activity 2: Pointing game

Display the school flashcards (27–32) and the toy flashcards (35–40) on the walls. Say, e.g. *Point to the eraser. Point to the table. Point to the car*. Give the instructions quickly, one after another. Pupils point.

Page 19

● Extra activity: Colour game

Show eleven crayons (one of each colour) to the class and hide them in your desk. Secretly take one and put it behind your back. Pupils ask questions to guess, e.g. *Is it red?* Answer *Yes, it is. / No, it isn't*. The pupil who guesses correctly comes to the front to choose a colour. Repeat.

Page 20

● Extra activity: True or false

Place the toy flashcards (35–40) and the school flashcards (27–32) around the room, e.g. the doll under the desk. Pupils can help you. Pupils stand up. When you say a true sentence, pupils put their hands in the air. When you say a false sentence, pupils stay still. Say sentences quickly, one after another, e.g. *The bike is on the chair. The pen is under the table*. Pupils who do the wrong action sit down. Continue until there is a small group of winners.

Page 21

● Extra activity 1: Where is it?

Pupils take out their sentence wheels from Photocopiable 3A. (If they didn't make them in the previous lesson, they can make them now.) Line up the wheels to make a sentence. Pupils guess by asking, e.g. *Is the train next to the bag?* The pupil who guesses correctly is the caller. Pupils play in pairs or in fours.

● Extra activity 2: Guessing game

Play a guessing game with the class. Place classroom objects around the room where they are in, on, under and next to other objects. Do it so pupils don't notice (if you can). Divide the class into two teams. Say, e.g. *It's pink. It's under a chair.* Pupils look around for the object, e.g. eraser. The first pupil to guess correctly wins a point for their team. Continue until all the objects have been found. The team with the most points is the winner.

Page 22

● Extra activity 1: Board slap

Play Board slap from page 8 Extra activity 1 using the toy flashcards (35–40), the school flashcards (27–32) and the number flashcards (9–18).

● Extra activity 2: Snap!

Photocopiable 3B. **Either** pupils take out the envelopes with their toy cards, **or** hand out the photocopies for pupils to make the cards (see T95 and T99). Pupils colour the objects on the cards as they wish.

Pupils work in fours. They place the cards face down on the table. They take turns to turn over two cards and say what they are, e.g. *A blue train, A red doll.* If the objects and/or the colours match, the pupil takes the two cards. If not, the pupil turns them face down again and it's the next pupil's turn. The player with the most cards is the winner.

Page 23

● Extra activity 1: Role play

Pupils work in threes: Marie, Maskman and Monty. Play the CD of the story again (CD1, 51). Pause after each picture for pupils to repeat in chorus in role. Pupils mime the actions as they speak. Pupils change roles. Repeat.

More confident threes can come to the front and perform their role plays for the class.

● Extra activity 2: Say and mime

Review the actions for the prepositions. Play a game like Scissors, paper, stone. Hold your hands behind your back and say *In, on, under, next to.* Just after you say *next to*, put your hands in front of you, showing one of the preposition mimes from page T20 Presentation. Hold your hands behind your back again, and say the same rhyme, but do a different action at the end. Pupils join in. They hold their hands behind their backs, chant with you and then show a preposition mime. If it's the same as you, they stay in the game. If it's different, they sit down for one turn. Repeat.

Unit 4

Page 24

● Extra activity: True or false game

Pupils stand up next to their chairs. Say sentences in turn, e.g. *Stella is her sister. Simon is her father.* Pupils sit on the floor when the sentence is correct. They sit on their chairs when it's incorrect. Everyone plays the game until the end.

Page 25

● Extra activity 1: Team game

Put the flashcard of Stella (3) in the centre of the board. Put the other family flashcards (1, 2, 4, 5, 45, 46) around Stella. Make two teams. Teams line up facing the board. Call out, e.g. *Her mother.* The first pupil in each team races to the board to touch the correct flashcard. Award a point to the first pupil to touch the correct card. The two pupils go to the back of their lines. Repeat.

● Extra activity 2: Family chant

Teach the following chant. Display the family flashcards (1–5, 45, 46). Pupils clap each line and then point to the flashcard when they say the name.

She's her mother, mother, mother,

She's her mother, Mrs Star.

She's her sister, sister, sister,

She's her sister, Suzy Star.

He's her father, father, father,

He's her father, Mr Star.

He's her brother, brother, brother,

He's her brother, Simon Star.

She's her grandma, grandma, grandma,

She's her grandma, Grandma Star.

He's her grandpa, grandpa, grandpa,

He's her grandpa, Grandpa Star.

Page 26

● Extra activity: What's missing?

Display the family flashcards (1–5, 45, 46) on the board. Say *Put your heads on your desks and close your eyes.* Check that pupils aren't looking and then take away one flashcard. Say *Open your eyes. What's missing?* Pupils answer. Show the flashcard when they guess correctly. Repeat, removing a different flashcard each time.

Page 27

● Extra activity 1: Team mimes

Place two chairs at the front, with the backs facing the board. Make two teams. Invite one member of each team to come and sit in a chair. Stick an adjective flashcard on the board. The class can see it, but the two pupils in the chairs can't. Make sure they don't turn around. Pupils in the teams mime the adjective. The first pupil in the chair to say the correct adjective wins a point for their team. Repeat with other pupils and other adjectives.

● Extra activity 2: Record it!

Practise the song from Pupil's Book page 27 Activity 7 (CD2, 11) again with the students. Tell them you are going to record them. Record them, using a cassette recorder or a video recorder. Play the recording back to the class.

Page 28

● Extra activity 1: Body shapes

Review the phonemes /s/, /m/, /t/, /b/, /d/ and the letters (s, p, t, b, d). Pupils work in groups of three. The three of them make the shape of one or more of the letters with their bodies. Groups demonstrate to the class.

● Extra activity 2: What's in my bag?

Place about five small known objects in a bag, e.g. pencil, small book, small ball, ruler, eraser. Don't let pupils see what you put in the bag. Invite a pupil to come and put their hand in the bag. They don't look. They feel the object and guess what it is. The pupil takes it out to check. Repeat with the other objects.

Page 29

● Extra activity 1: Board game

Photocopiable 4. If pupils have not played before, follow the instructions on page T95.

If pupils have played before, make pairs and hand out the dice, boards and a coin to each pair. Monitor pupils as they are playing. The first player to reach the Finish is the winner. Pairs who finish first can play again.

● Extra activity 2: Disappearing flashcards

Play the Disappearing flashcards game from Page 18 Extra activity 1 with some of the character flashcards (1–8, 33, 34) and a selection of the other flashcards (maximum of 12).

Page 30

● Extra activity: Colours challenge

Pupils use their colour knowledge to challenge the class. As with the palette in Pupil's Book Activity 1, pupils colour two patches of colour on a piece of white paper, taking care to leave a space in the middle. Pupils pass the paper to another pupil to colour in the new colour (made by mixing the two together). The pupil colours, and then says the complete sentence, e.g. *Yellow and blue is green*.

Page 31

● Extra activity: Situations mime game

Pupils work in small groups to make up situations to mime to the group. Tell them to make up a situation in which there is a compliment, an apology or an offer. Write *Wow!, I'm sorry!* and *Here you are* on the board. Monitor and check that pupils are choosing one of the three situations. Choose groups to do their mime for the class. The rest of the class say what the situation is by reading a phrase from the board: a compliment (*Wow!*), an apology (*I'm sorry*) or an offer (*Here you are*).

Review Units 1–4

Page 32

● Extra activity 1: Play a game

Play one of the photocopiable games from Units 1–4 with the pupils.

● Extra activity 2: Sing a song or do a chant

Choose one of the songs or chants from Units 1–4 to do with the pupils. Do it without the CD.

Page 33

● Extra activity 1: Chant

Teach the following chant to the pupils, to review the adjectives and the actions. Divide the class into two for the questions and answers. Change roles and do the chant again.

Who is happy, happy, happy?

Who is happy now?

We are happy, happy, happy.

We are happy now.

Repeat for *sad, young, old, ugly, beautiful*.

● Extra activity 2: Object puzzle

Tell pupils to put the following objects on their desks: bag, eraser, blue pencil, red pencil, green pencil, book. Give pupils instructions to follow, e.g. *Put the blue pencil in your bag. Put your bag under your chair. Put the red pencil next to the eraser. Put the green pencil on your chair*. Pupils take turns to be the callers and then continue the game in pairs.

Unit 5

Page 34

● Extra activity: Board slap

Play Board slap from page 8 Extra activity 1 using the pet flashcards (47–52).

Page 35

● Extra activity: Wordsnake

Write *computertraincar* on the board. Elicit and circle the words (computer, train, car).

Make pairs. Display the large wordsnake on poster paper: *horsedollpencatballdogeraserbookmousebikefishchairbird*. Pupils race to find the words. Check by inviting pairs to say the words and to come and circle them on the snake.

Page 36

● Extra activity 1: Class game

Draw a 3 x 3 grid on the board. Number the squares (1–9). Stick a flashcard face down in each square. Choose from the characters (1–5, 45, 46) and the pets (47–52). Make two teams: Horses and Cats. Cats choose a square. Turn over the flashcard. Ask, e.g. *What/Who is it / are they? or Is it/he/she big?* If they answer correctly, draw a large *O* in the square. If not, replace the flashcard with another one. Horses choose a square. Continue until one team has a line of *O*s or *X*s, or all the squares have *X*s or *O*s.

● Extra activity 2: Spot the difference

Brainstorm the twelve known adjectives (*long, ugly, etc.*). Make pairs. Hand out Photocopiable 5A and B to each pair. Pupils look at the pictures and find differences. If pupils used the material for page 35, they find more differences (underlined below). If not, they can find the ones from the previous lesson, **plus** the ones below. They circle them in pencil. Check with the class.

Key:

A: One cat under a clean table

A: Big old horse

A: Six dogs, three big, three small

A: Four mice

A: One fish

A: Eight beautiful small birds

B: Two cats on a dirty table

B: Beautiful small horse

B: Five dogs, one long, four short

B: One mouse

B: Two fish (one small)

B: Nine beautiful small birds

Page 37

● Extra activity 1: What is it?

Place a selection of classroom objects around the room. Look thoughtful. Say *I'm thinking of something. It's red and long. What is it?* (pencil). Pupils take turns to guess. Repeat with the other objects, practising as many adjectives as you can.

● Extra activity 2: Colour and say

Pupils work in pairs. Each pupil draws a new route in Activity Book page 36 Activity 6, using a green pencil. They don't look at each other's routes. They sit facing one another, holding their books up so their partner can't see. Pupils take turns to say their route and draw their friend's route, using a yellow pencil. They check together. Early finishers can colour the pictures.

Page 38

● Extra activity 1: Draw and write

Review *favourite* by holding up pictures of favourite toys from Unit 3. Display the pet flashcards, look thoughtful and point to, e.g. the cat. Say *My favourite pet's a cat*. Nominate pupils and say (Name), *what's your favourite pet?* The pupil chooses from the pets on the board. Repeat with different pupils. Say *Draw your favourite pet and write the word*. Write the words for the pets under each flashcard on the board for pupils to copy (or call volunteers to the board to write the words). Pupils draw, write and then colour. Make a class display of their pictures.

● Extra activity 2: Our favourite dogs

Talk about the dogs in Activity Book page 38 Activity 9. Draw a simple 4 row x 7 column grid on the board for pupils. At the top of each column (except the first), write the numbers 1–6 to match the numbers of the dogs. In three of the squares on the left of the rows, write the names of three pupils. In the other square, write your name. Ask one of the pupils whose name you've written: *What's your favourite dog?* The pupil responds with a number corresponding to the picture, e.g. *Number 4*. Put a tick in square 4 for this pupil. Repeat with the other two pupils. Then put a tick in one of the squares for yourself.

Pupils copy the empty grid and ask and answer in groups of four. They tick for themselves first.

Do a show of hands to find out which dog is the class's favourite.

Page 39

● Extra activity 1: Bingo game

Place the pet flashcards (47–52) on the board. Add other flashcards to make a total of ten, e.g. two colours and two school. Write a number between 1 and 10 under each flashcard. Demonstrate the game for pupils.

Pupils draw a 2 x 2 grid in their notebooks. They choose four pets/colours/school words from the board and in pencil write the corresponding number in each square. Say, e.g. *Horse*. Pupils who have the number corresponding to the horse make a line through the square. Continue calling out the other words. When pupils have crossed out all four squares, they shout *Bingo!*

Repeat.

● Extra activity 2: Match the halves

Display the large piece of paper with the split words: *do – sh, ho – se, fi – rd, mou – t, bi – rse, ca – g*. Don't tell pupils what to do. Give them time to work it out. As they do, invite individuals to come and draw lines to make the whole word each time.

Key: dog, horse, fish, mouse, bird, cat

Unit 6

Page 40

● Extra activity 1: Read and point

Pupils use Pupil's Book page 40 Activity 1. They take it in turns to point to the words and to the part of their face, e.g. Pupil A points to the word *Eyes*, and Pupil B points to his/her eyes and says *Eyes*.

● Extra activity 2: Chant

Teach the following chant. As you say the words, count the numbers on your fingers and at the end touch the face part. Pupils copy.

Make two groups. Everyone counts the numbers. One group asks the questions, and the other replies. Change roles and repeat.

*One, two, three, four, five,
Where's your eye? Where's your eye?*

*One, two, three, four, five,
Here's my eye. Here's my eye.*

Repeat for *nose, ear, mouth, teeth* (plural *Where're ... / Here're ...*).

Page 41

● Extra activity: Swapping game

Display the face flashcards (53–58) on the board. Under each one, write the wrong word, e.g. under *eye*, write *Ear*. Say *Is this OK?* In pairs, pupils match the words with the pictures. One pair comes to the board and swaps two flashcards around so that one flashcard is above the correct word. Repeat with other pairs. Stop when all are correct.

Repeat.

Page 42

● Extra activity 1: Toy families

Pupils take out their toy cards from Photocopiable 3B. Quickly review the words by saying, e.g. *Hold up the train*.

Pupils work in fours. They put the 24 cards face down and mix them up. Each player takes six cards and looks at them. The aim is to get four toys the same. Pupil 1 asks any other player for a card by saying, e.g. *Have you got a train?* Pupil 2 replies *Yes/No*. If he/she has, he/she hands it to Pupil 1. Pupil 2 asks for a card. When a player has a set of four, he/she puts them down on the table. The player(s) with the most sets at the end is/are the winners.

● Extra activity 2: TPR game

Play a TPR game with the class. Demonstrate the game. Say, e.g. *Everyone with blue eyes, stand up. Everyone with short hair, point to the window*. Continue, recycling the adjectives, face and body parts and instructions.

Page 43

● Extra activity 1: Group song

Make groups of six. Groups will need their troll stick puppets from Photocopiable 6, or give them one of the troll faces from the warmer. They choose one of the puppets in their group. They practise singing the song from Pupil's Book page 43 Activity 7 (CD2, 49) about their puppet and changing the words to match the colours. Select more confident groups to come and sing their song to the rest of the class. Help the groups as they are singing to the class.

● Extra activity 2: Guess the word

Draw six circles on the board. In each one, write the letters for a face word. Don't write them in the right order. Put pupils into pairs. They write the words correctly, without looking in their books. Check by asking pairs to say the word, e.g. *Mouth* and point to their mouth.

Page 44

● Extra activity 1: Spin and draw a monster

Pupils take out their number spinners from Review Units 1–4. Display the face part flashcards (53–58). Write a number between 1 and 6 under each one. Demonstrate the game. Spin a spinner, and say the number and the face part, e.g. *Two. A nose*. Draw a nose. Spin the spinner again. Say the number and the body part, e.g. *Four. Three eyes* and draw them to continue the monster's face. If you get the same number twice, miss a turn.

Make groups of four. Pupils take it in turns to spin and draw. The first in each group to draw the complete face is the winner.

● Extra activity 2: Board slap

Play Board slap from page 8 Extra activity 1 using some /fr/, /gr/, /br/ words.

Page 45

● Extra activity 1: Role play

Pupils work in groups of four. Play the CD of the story from Pupil's Book page 45 Activity 11 (CD2, 54) again. Groups do the actions along with the CD. More confident groups can role play the story for the class.

● Extra activity 2: Puppet game

Pupils take out their stick puppets from Photocopiable 6 and hold them up. Play an action game. Demonstrate it first with the class. Say, e.g. *Puppets with blue hair, stand up*. Pupils stand up if their puppets have blue hair. Continue combining face parts and actions to give pupils all a chance to move, e.g. *big mouth / point to the door, small ears / sit down, red mouth / touch your nose*.

Page 46

● Extra activity: Guess the sense game

Put the pupils into five groups, one for each sense. Give the groups the name of their sense on a piece of paper and tell them to keep it secret. In their groups, pupils think up things to draw to represent that sense. Pupils help each other with the vocabulary. A pupil from each group presents the pictures and says the words. The other pupils think in their groups and put their hands up to guess the sense the other group is describing. Repeat with the other groups.

Page 47

● Extra activity: Sentence jumble

Write these sentences on the board, but mixing up the order of the words, e.g. *is cat My beautiful*:

My cat is beautiful.

I feed my fish.

I look after my pet.

I wash my horse.

My fish is beautiful.

This is my dog.

Pupils write the correct sentences and put their hands up when they have the answer.

Unit 7

Page 48

● Extra activity 1: Animal mime

Pupils stand in a space. Play the CD of lively music. Pupils move around. Pause the CD. Say *Now be elephants*. Pupils mime elephants. Clap your hands. Pupils stop. Restart the CD. Pupils move again. Repeat for the other animals. Check pupils are paying close attention by saying the same animal again.

● Extra activity 2: Word chains

Play a word game around the class. Start the chain. Say *I've got a snake*. Pupil 1 says *I've got a snake and a giraffe*. Pupil 2 says *I've got a snake, a giraffe and an elephant*. Continue for two or three more goes (pupils can use wild animals and pets). Clap your hands. Say *School things*. The next pupil starts a chain with school things. Repeat with other word families, e.g. face parts.

Page 49

● Extra activity 1: Word shapes

Display the animal words cut in half and stuck on a large piece of paper. Say *Look at this. What animals are they?* Pupils work in pairs. They match the word halves. Check with the class, writing the other half in a different colour from the original.

● Extra activity 2: Draw the animals

Draw two rows of four simple rectangular frames on the board. Number the frames in each row 1 to 4. Say *Copy these boxes. Write numbers 1, 2, 3, 4*. Pupils draw the frames in their notebooks.

Draw a wild animal (giraffe, crocodile, etc.) in each frame in the top row on the board. Say *Hide your notebook. Draw animals in the boxes at the top. Choose different animals*. Pupils draw four animals in the boxes in the top row in their notebooks. Make sure they choose different animals from you and that they keep their pictures secret. Set a time limit of 3–5 minutes. While pupils are working, draw four animals in boxes numbered 1 to 4 (e.g. a tiger in box 1, a giraffe in box 2) on a piece of paper.

Pupils work in pairs. They sit facing one another, holding their notebooks up so their partner can't see. Demonstrate the language to the pupils. Hold up your piece of paper (with the pictures hidden) and say *In number 1, I've got a tiger. You draw a tiger in number 1*. Pupils take turns, e.g. Pupil A says a sentence and Pupil B draws the animal in the correct box. Set a time limit of five minutes.

Pupils look and check.

Page 50

● Extra activity 1: Memory game

Place 12 classroom objects, e.g. two erasers, seven pencils (two red, two green, three yellow) and three books, where pupils can see them. Pupils look for one minute. Cover the objects with a cloth. Ask questions and pupils write the answers, e.g. *How many books? How many yellow pencils?* Pupils check in pairs. Take the cloth off for pupils to check.

● Extra activity 2: Animals

Display the wild animal flashcards (59–65) and pet flashcards (47–52). Make two teams. Place two chairs at the front, with backs facing the board. A pupil from each team sits on each chair. They don't look at the board. Write an animal name on the board, e.g. *Hippos*. Pupils in the teams shout clues to their team mates on the chairs, e.g. *They've got big mouths. They've got short tails. They've got small ears*. The first pupil on the chair to guess correctly wins a point. Two new team members come to the chairs. Repeat. The team with the most points at the end is the winner.

Page 51

● Extra activity: More wordsnakes

Pupils work individually. They use their picture dictionaries to make a wordsnake for another pupil in the class. Give them a limit of words to hide, e.g. six. Remind them to add extra letters to make it more difficult. Pupils swap wordsnakes, circle the words and then check in pairs.

Page 52

● Extra activity 1: Sound families

Display flashcards (picture side) for all the pictures in Activity Book page 52 Activity 8 around the edge of the board. Draw three large circles across the middle of the board. Place an /a/ picture in the first circle, an /e/ picture in the second circle, and an /i/ picture in the third circle.

Pupils work in pairs and decide what other flashcards to put in the circles to make the sound families.

Check by asking pupils to come and place one of the flashcards in one of the circles and to say the vowel sound. Ask the class for confirmation.

● Extra activity 2: Colour dominoes

Photocopiable 7. Make groups of three. Hand out the domino envelopes. Pupils each take six cards and colour the animals, using unusual colours and more than one colour for each animal.

Pupils play the domino game again. They say the animal's colour as they make the match, e.g. *A green and purple snake*. They play the game in the same way as before.

Page 53

● Extra activity 1: Crazy animals

Show the picture of a 'sniger'. Tell pupils it's half snake and half tiger. Say, e.g. *Snigers have got short legs, black and yellow bodies, long tails and a lot of teeth, and they haven't got ears*.

Show pupils how you made the name of the new animal from two animals. Elicit or suggest others, e.g. *Hiraffe, crococo, telephant, girger, eleraffe*.

Pupils work in pairs. They invent a new animal, draw it and write the name. Pupils show their animal to other pairs and describe it. More confident pupils show theirs to the class.

Display the pictures.

● Extra activity 2: Animal bingo

Play the Bingo game from Page 39 Extra activity 1, but using wild animals (59–65) and pets (47–52).

Unit 8

Page 54

● Extra activity 1: Memory game

Make pairs: A and B. Place the clothes flashcards (66–71), plus *computer* (38), *crocodile* (59), *ball* (36) and *chair* (29) on the board. Write a number between 1 and 10 under each one. After 30 seconds, Pupil B turns to face the back of the class (so he/she can't see the board). Pupil A asks, e.g. *What's number 6? What colour are the trousers?* Pupil B answers. Pupil A keeps a score of correct answers. After one minute, clap your hands. Pupil B looks at the board to check. Move the flashcards. Repeat with Pupil B asking and Pupil A answering. The pupil with the highest score in each pair is the winner.

● Extra activity 2: How many?

Make groups of four. They look at the clothes they are all wearing. Say *Count your clothes*. Point to, e.g. the skirts, and say *Count. How many skirts?* Pupils count the clothes in their group. Pupils respond, e.g. *We've got two skirts. We haven't got trousers.*

Elicit the numbers from groups. Draw a simple grid on the board (6 for the clothes items x the number of groups) and record the numbers from each group. Comment on the information like this: *We've got a lot of socks. We haven't got jackets.*

Page 55

● Extra activity 1: Flashcard game

Four pupils come to the front. Each one chooses a clothes flashcard (from 66–71). They hold them behind their backs. Ask one pupil questions, e.g. *Have you got a blue T-shirt?* Continue asking until the pupil responds *Yes, I have*. The class ask questions of the other three pupils in the same way.

The pupils sit down. Make teams of four. Each team chooses an animal name, e.g. *Cats*. Write these on the board. One team comes to the front and takes and holds behind their backs four flashcards. A member of another team comes and asks questions, e.g. *Have you got red trousers?* to guess the clothes. He/She can ask five questions. Repeat for other team members.

Scoring: One point for each grammatically correct question, five points if the pupil answers yes on the first question, four points if it's on the second and so on.

Teams take turns. The team with the most points is the winner.

● Extra activity 2: Snap!

Play the CD of lively music. Pupils skip around the room. Pause the CD. Pupils find a partner and take turns to say what their favourite clothes are from Activity Book page 55 Activity 4. If any are the same, they shout *Snap!* Elicit from pupils: *Our favourite clothes are ...* Start the CD again. Pupils move on. Repeat.

Page 56

● Extra activity 1: Who is it?

Say two or three sentences to describe a pupil in the class, e.g. *Who is it? She's got blue eyes. She's got long, brown hair. She's got black shoes.* Pupils take turns to guess. They have three guesses. If they don't guess, you win a point.

Pupils work in pairs. Each pair looks around and thinks of three sentences about one of the pupils in the class. Elicit the sentences from one of the pairs. The other pupils have three guesses. If they don't guess, the pair wins a point. If a pair guesses correctly, they win a point.

Continue.

● Extra activity 2: Look and remember

Pupils look at the pictures in Activity Book page 56 Activity 5 for 30 seconds. They close their books. Ask questions, e.g. *1. Has May got socks? 2. Has Tony got a cat?* Pupils write the number in their notebooks and a tick or a cross for 'yes' or 'no'. Ask ten questions.

Pupils exchange notebooks for checking. Ask the questions again. Elicit the correct response (*Yes, he/she has. / No, he/she hasn't.*). Pupils mark their friend's work.

Page 57

● Extra activity 1: Do as I do

Pupils each draw a large 2 x 3 grid in their notebooks. They number the squares 1–6. They work in pairs, A and B. They place their notebooks so they can't see each other's grids. Pupil A places their cards from Photocopiable 8 in the squares. Pupil B asks questions, e.g. *What have you got in number 2?* and then places their cards in the same place. At the end, they check to see if the cards are in the same places. Pupils swap, with Pupil B placing the cards and Pupil A asking.

● Extra activity 2: Fashion show

Demonstrate the activity for the pupils. Ask a pupil to come up and walk in front of the class. Say *This is (name). She's got black shoes* (the pupil does a flourish with her shoes). *She's got a white shirt* (the pupil shows off her shirt). *She's got brown hair* (the pupil shakes her head), etc. Repeat with another pupil.

Pupils work in groups of four. They choose one person for their fashion show. Each pupil chooses one sentence to say about him/her. Groups take it in turns to do the fashion show in front of the class. The show can be videoed.

Page 58

● Extra activity 1: Spot the sound

Display flashcards of words with the sounds /a/, /e/, /i/ and /o/ on the board, picture side up (e.g. *cat, black, bag, pen, ten, red, fish, hippo, six, orange, doll, crocodile*). Make two or three teams. Teams line up with one person in each team at the front, nearest to the board. Say *Listen and find cards with the sounds*. Say one of the sounds (e.g. /i/). The pupil from each team who is near the board has to come to the board and take one of the flashcards with that sound (e.g. the hippo). Whoever does this first gets a point for their team. The pupils who were at the front move to the back of the line. Repeat with the pupils who are now at the front. Continue in this way, keeping score. Replace the flashcards so that all the team members get a turn. The winning team is the one with the most points at the end of the game (or after a time limit set by you).

● Extra activity 2: Matching game

Pupils play a matching game in groups of four, using their cards from Photocopiable 8. Pupils take out their six cards and place them face down on the desk. They mix the 24 cards around. The first player turns over two cards and says what they are, e.g. *Yellow socks, a red shirt*. If the cards are the same, the player keeps them. If they are different, the player turns them face down again. Play moves to the next player. Play continues until all the cards are matched. The player with the most pairs is the winner. Remind them of the game language *It's my turn / It's your turn*.

Page 59

● Extra activity 1: Role play

Pupils work in groups of four. Play the story from Pupil's Book page 59 Activity 11, CD3, 31. They speak and act along with the CD. Give them time to practise without the CD. Monitor the groups and help where necessary. More confident pupils can come to the front and perform.

● Extra activity 2: Word halves

Display the large piece of paper with the split words on it: *jac – sers, sh – shirt, sk – ket, so – irt, trou – oes, T – cks*. Don't tell pupils what to do. Give them time to work it out. As they work it out, invite individuals to come and draw lines to make the whole word each time. Another pupil then comes and places the flashcard of the item next to the word.

Elicit each word from the class.

Page 60

● Extra activity: Animal gap fill

Pupils work in pairs to make their own gap fill about one of the animals. They can use the model in Activity Book page 60 Activity 2 to help them.

You might like to revise some colour and body parts vocabulary to help the pupils.

Check the texts and choose one or two to write on the board for the class to do together.

Page 61

Extra activity: Polluted or unspoilt picture?

Pupils work in pairs. Give each pair a photo of a place, e.g. a park, river or forest, which is either polluted or unspoilt. Pupils use the language and vocabulary that they have practised in the lesson to write two or three sentences about their picture in their notebooks.

Go around checking the sentences and then choose volunteer pairs to talk about their pictures in front of the class. Pupils do the talk without showing their picture and the rest of the class have to guess what the picture shows (they say *happy* or *sad*). Then the pair show the picture.

Review Units 5–8

Page 62

● Extra activity 1: Play a game

Play one of the games from Units 5–8 with the pupils.

● Extra activity 2: Sing a song or do a chant

Choose one of the songs or chants from Units 5–8 to do with the pupils. Do it without the CD but with the actions.

Page 63

● Extra activity 1: Guess the square

Make pairs. Pupils play a guessing game using the board on Pupil's Book page 63. Pupil A chooses a square without telling his/her partner which it is. He/She makes one or two sentences as a clue, e.g. *It's small and grey. It's got four legs*. Pupil B says the word and points to the correct picture (e.g. *Mouse!*). Then they swap roles.

● Extra activity 2: Consequences

Prepare sheets with text and lines as shown below and photocopy one for each pupil:

1. It's _____ (colour).

2. It's got a _____ (big/small) head.

3. It's got _____ (four/two/no) legs.

Make groups of three. Each pupil needs a pencil. Hand out the sheets you have prepared. Say *Write. Then fold. Write. Then fold. It's a secret!* Each pupil completes the first sentence with a word. They fold the paper so their friend can't see and pass it to the left. Continue until all the sentences are complete and pupils get their original paper back. Pupils unfold the paper and take turns to read the description of their animal to the rest of the group.

Unit 9

Page 64

● Extra activity 1: Group game

Demonstrate the game. Six pupils come to the front. Make a group of seven, including yourself. Elicit an action from the class, e.g. *Ride a bike*. Mime riding a bike. Say a pupil's name in the group and another action, e.g. *Maria, play tennis*. 'Maria' mimes playing tennis and then says the name of another pupil in the group and another action. Repeat for all the actions, encouraging pupils to name each other at

random (not in order around the circle) and to repeat some of the actions.

In groups, pupils play the game.

● Extra activity 2: Mime game

Show the action flashcards (72–78), word side, quickly to pupils. Choose two pupils. One mimes the action; the other says it. Repeat. Use the flashcards more than once and include as many pupils as you can. Display the flashcards, word side, and point to each one. Pupils chorus the action.

Page 65

● Extra activity: Whisper game

Make four teams. Teams line up, facing the board. Whisper a different action to the first member of each team, e.g. *Swim. Play the piano*, etc. Say *Ready, steady, GO!* The first member of each team whispers the action to the next member and so on to the end of the line. The pupil at the end runs to the front and mimes the action. Elicit what the actions are from the members of the team. Award points for the correct mime and for the correct phrase. The pupil from the back comes to the front of the team. Repeat. The team with the most points at the end is the winner.

Page 66

● Extra activity 1: Can you or can't you?

Photocopiable 9a. Pupils need only the picture cards. Make groups of four. Pupils put the 24 cards face down in front of them. Pupil A turns over a card and places it next to him/her and says, e.g. *I can swim* or *I can't swim*. Pupil A says to one of the group *Can you?* The pupil answers *Yes* or *No*. Pupil B turns over a card and does the same. Play continues until all cards have been turned over.

Say to one group *Tell me about* (group member, e.g. *Peter*). *Can he swim?* 'Peter' doesn't reply. The other group members answer. Check other groups in the same way. Pupils put their cards back into their envelopes.

● Extra activity 2: Class survey

Draw a 6-column x 2-row grid on the board. Write one action from Activity Book page 66 Activity 5 for each column. Write *can* next to the first row and *can't* next to the second. Make groups of six. Pupils report the numbers for their group for each activity, e.g. *Six can swim. Three can't ride a bike*. Write the totals, e.g. *25* in the grid. Circle two actions: one which most pupils can do, and one which most pupils can't.

Page 67

● Extra activity 1: Can you?

Ask a pupil *Can you swim?* The pupil replies, e.g. *Yes, I can*. This pupil then asks another pupil a question about what they can do and the activity continues around the class. Encourage pupils to ask each other at random (not in desk order). Focus pupils on the use of the strong form of *Can* in questions and responses, e.g. *Can you swim?* *Yes, I can*, and the weak form in statements, e.g. *I can ride a bike*.

● Extra activity 2: Place the cards

Pupils take out copies of Photocopiable 9a. They need only the word cards. Draw a simple 6 x 2 grid on the board for them to copy. Along the top, write the numbers 1–6. At the side, write *Can* next to the top row and *Can't* next to the bottom row. Say six sentences, e.g. *1. I can't swim. 2. I can ride a bike. 3. I can't play the guitar. 4. I can't play basketball*. Pupils listen and place the cards in the right place on their grids. Make sure you say the sentences at normal speed, so that *can* sounds very short. They check in pairs. Check with the class, using the flashcards.

Pupils play the game in pairs, taking turns to place cards in their grid and to say sentences about them for their partner to listen and place. Remind them to sit facing one another, hiding their books so their partner can't see.

Page 68

● Extra activity 1: How many words?

Make teams of four or five. Pupils have their books closed. Each team chooses someone to write. Pupils in their teams think of as many words with the sound *l* as they can, and one person writes them on a piece of paper. Set a time limit for the game. When the time is up, the team with the most correct words wins. See how many words the class can think of working together – elicit the words from the winning team and write them on the board; then ask the other teams to come up and write down words they thought of that the winning team didn't write. Examples of words with *l* are: *hello, look, listen, yellow, purple, blue, black, table, pencil, ball, football, basketball, doll, family, ugly, long, clean, beautiful, old, crocodile, elephant, animal, leg, tail, play.*

Do not allow words where the letter *l* is silent or forms part of a vowel sound (e.g. *walk, talk*), as the game is about sounds not spelling.

● Extra activity 2: Clapping game

Display the action flashcards (72–78) on the board at random. Review them by asking around the class, e.g. *Can you swim? Can you ride a bike?*

Teach the following chant to the class. Pause after *can/play/ride* in the first two lines of each verse. During the pause, clap twice loudly. In the chorus, start very quietly and then get louder and louder.

Elicit other actions to complete the verses and chant the new verses with the class (*can ... read, write, play the piano/basketball/tennis, ride an elephant*).

<i>I can ... swim.</i>	<i>I can ride ... a bike.</i>
<i>I can ... draw.</i>	<i>I can ride ... a horse.</i>
<i>Yes, I can. Yes, I can.</i>	<i>Yes, I can. Yes, I can.</i>
<i>Yes, I can. Yes, I can.</i>	<i>Yes, I can. Yes, I can.</i>

<i>I can play ... football.</i>
<i>I can play ... the guitar.</i>
<i>Yes, I can. Yes, I can.</i>
<i>Yes, I can. Yes, I can.</i>

Page 69

● Extra activity 1: Snap

Play a game of Snap, using the cards from Photocopiable 9a. Pupils play in pairs. Each pupil takes out their 12 cards, shuffles them and holds them so that they can't see them (their partner can't see them either). Pupils count together: 1, 2, 3. At the count of 3, they both put the top card from their pile face up on the desk. They continue like this until there is a match (two pictures the same, two phrases the same, or a matching phrase and picture). Then pupils shout *Snap!* The first to say it says what the cards are (e.g. *ride a bike*), and then takes all the cards in both face-up piles and puts them at the back of the cards in their hand. Play continues. Set a time limit for the game. The first player to win all the cards from his/her partner is the winner.

● Extra activity 2: Matching cards

Pupils take out the cards from Photocopiable 9a. They colour the picture cards. They then stick the cards in their notebooks, placing the word card underneath the picture card. They write one (or two) sentence(s) under each one, e.g. *I can ride a bike. My bike is blue. I can't swim.*

Unit 10

Page 70

● Extra activity 1: Bingo

Play the Bingo game from Page 39 Extra activity 1, but using *bus, lorry, motorbike, helicopter, plane, boat (79–84); horse (50), car (35), train (40).*

● Extra activity 2: Ask and answer

Pupils use the material in Activity Book page 70 Activity 1 for a game. They work in pairs and take turns to ask questions about the pictures, e.g. *What colour's the lorry? What's yellow?* Extend to a team game. Make two teams. Members of the teams take turns to ask a question of the other team. Award one point for a correct question and one point for a correct answer. The team with the most points at the end is the winner.

Page 71

● Extra activity: Tongue twister

Teach the following tongue twister. Say it slowly as a class first, then go faster and faster. Make pairs. Pairs practise saying it, seeing how fast they can say it and still say it correctly.

Invite pairs to come to the front and say it to the class. Time the pairs with a stopwatch. The pair who says it fastest is the winner.

Red lorry, yellow lorry

Page 72

● Extra activity 1: Run and touch

Spread the 18 flashcards (*elephant, T-shirt, trousers, skirt, shoes, giraffe, snake, tiger, crocodile, jacket, hippo, socks*, plus the six funfair ones) word side at random across the board. Make three or four teams. They line up, facing the board. Say one of the words, e.g. *Giraffe*. The pupils at the front of each team run to the board. The first to touch *Giraffe* wins it for their team. These pupils go to the back of the line and it's the next pupils' turn. Continue until all the cards have been 'won'. The team with the most cards is the winner.

● Extra activity 2: Memory game

Display the 18 flashcards from Extra activity 1 on the board again, this time picture side showing. Pupils put their heads on their desks, close their eyes and count to ten. Remove one of the flashcards. Pupils say which one is missing. Show them the card. Place it on the board again. Repeat, removing other flashcards.

Page 73

● Extra activity 1: Funfair

Photocopiable 10. Pupils play the Funfair game again from page T71. This time pupils play in groups of four. Hand out a game board to each group of four. They also need a coin and coloured counters.

Demonstrate the game quickly to the class. They put their counters on *Start*. The first player tosses the coin: heads they move one space, tails two. The pupil moves the counter to the space and says what it is, e.g. *A green helicopter*. If pupils make a mistake, e.g. say the wrong colour or the wrong ride, they miss a turn. Pupils take turns to play. The player who gets to *Finish* first is the winner. Remind pupils of game language, e.g. *It's my turn. It's your turn. That's wrong! Miss a turn.*

Collect the game boards for use in another lesson.

● Extra activity 2: Word families

Display about 20 flashcards (word side) around the edges of the board from the following word families: funfair (79–84), clothes (66–71), wild animals (59–65), school (27–32). Make sure each set is missing at least one known word. Draw four large circles. Write *Funfair* in the centre of one circle. Invite a pupil to come up and point to one flashcard in this set. If the class agree, move it to the edge of the *Funfair* circle. Let the pupils work out what words go in the middle of the other circles: *Clothes, Wild animals, School*. When they tell you, write them in.

Invite pupils in turn to come and move one card to the correct family. When all the cards are in place, elicit one more word for each family (the card you left out).

Page 74

● Extra activity 1: Pointing game

Display the cards, each with a letter on (c, f, d, n) around the room, one on each wall. Pupils stand up. Call out the following words (in any order): *Face, fish, five, four, foot, feet, crocodile, computer, car, clothes, door, dog, doll, draw, nine, nose, night, number*. Pupils point to the card with the starting letter, e.g. when you say *Face*, they point to *f*. Call out the words quickly one after another to get pupils moving.

Make four teams. One team stands up. Call ten words, one after another, at random, for the team to point. If anyone makes a mistake, it's the end of the team's turn and they win the number of points up to that go: if they make a mistake on the seventh word, then they get six points. Repeat for the other teams. The team with the most points is the winner.

● Extra activity 2: My favourite funfair ride

Talk about the funfair with pupils, using the pictures in Pupil's Book page 74 Activity 10, and elicit which ride they like best. Supply other words if necessary. Pupils draw a picture of a funfair ride, colour it and write underneath, e.g. *My favourite is the blue helicopter*.

Pupils show and talk about their pictures to their friends. More confident pupils come to the front to show and talk about their pictures to the class.

Page 75

● Extra activity 1: Role play

Make groups of three. Pupils decide roles (Monty, Maskman, Sam). Play the CD of the story from Pupil's Book page 75 Activity 11 (CD4, 16) again. Pupils act out the story along with the CD, joining in when they can. Give pupils time to practise their role plays in their groups. Remind them to use the pictures in the book to help them. More confident pupils can act out parts of the story to the class.

Ask pupils who their hero is: Maskman or Monty. Take a vote from the class.

● Extra activity 2: Star card review

Pupils work in pairs. They take it in turns to choose a star card from a previous unit of the Activity Book and to test each other. One points to the words and the other says them. They help each other with words they don't remember. Monitor and help where necessary.

Page 76

● Extra activity: Sports guessing game

Pupils work together in pairs to write descriptions for the sports on Pupil's Book page 76. They write, e.g. *They've got a big boat. They're sitting in the boat. What are they doing?* Do the first one yourself as an example. Ask pupils to close their books. Choose pairs to read out their descriptions to the class. The rest of the pupils guess which sport they are describing (e.g. *Sailing*).

Page 77

● Extra activity: Pass the ball

Make two teams with an equal number of pupils in each. The members of each team pass a tennis ball or an orange around. They encourage each other to pass it as fast as possible, by saying *You can do it! Come on! Great!* The first team to pass the ball all the way round to the first person wins the game.

If your pupils do not mind physical contact, they can play this game without using their hands, by placing the ball under their chins and passing it from person to person in this way.

Unit 11

Page 78

● Extra activity: Whispering game

Display the room flashcards (85–90) on the board. Make four teams. They line up, facing the board. Whisper the name of a different room to the first pupil in each team. They whisper back along the line to the end. The pupil at the back runs to the front and touches the flashcard of their room. The first to touch the right card – and to say the room correctly when asked – wins a point for their team. The pupils from the end of the lines join the front of the teams. Repeat about four or five times with other words. The team with the most points at the end is the winner.

Page 79

● Extra activity 1: Matching game

Display the room flashcards (85–90), picture side. Write the name of a room under each one, but write the wrong names, e.g. *Living room* under the kitchen picture. Say *Is this OK?* Pupils say *No*. Ask one pupil to come and swap two cards so that one is correct, e.g. so the word *Kitchen* is under the kitchen picture. Ask other pupils to come and do the same until all the pictures and words match.

● Extra activity 2: Guessing game

Hand out Photocopiable 11 to pairs of pupils. They prepare the materials if they did not use them in the previous lesson.

Pupil A puts the house on the desk. Pupils sit facing one another, hiding their cards so their partner can't see them. Pupil B chooses six cards and hands them to Pupil A. Pupil A places them in rooms in the house. Pupil B has ten guesses to find the objects, e.g. *The trousers are in the bathroom*. After ten guesses, Pupil B writes the score (one point for each correct guess). Pupils swap roles. Pupil B takes the house and Pupil A chooses six object cards.

Pupils repeat. Elicit the scores from the class. The pupil(s) with the highest score is/are the winner(s). Collect the materials for use in another lesson.

Page 80

● Extra activity 1: Sentence halves

Pupils close their books. Display the prepared sentence halves (see Materials required on page T80) on the board. Don't put the correct ones next to each other. Write numbers 1–6 in red next to the sentence openings, and 1–6 in blue next to the sentence ends.

Pupils work in pairs. They write the numbers in their books to match the sentences, e.g. 1 (in red), 5 (in blue). Elicit the correct sentences. Pupils come to the board and move the two parts of the sentences together. Do a noticing activity, e.g. all sentences that have *-ing*.

● Extra activity 2: Draw and write

Pupils draw a picture of their friend doing an action (drawing, writing, etc.) and underneath they write *She's / He's ...-ing*. Pupils come to the front and show their pictures to the class and say, e.g. *This is Roberto. He's riding a bike*.

Page 81

● Extra activity 1: Role play

Make groups of eight. Hand out four room cards, each with the name of a room written on, to each group. Demonstrate the activity. Four pupils hold the room cards. Each pupil decides on a mime (what they're doing in the room). The other four pupils ask the class, e.g. *Where's Nicola?* 'Nicola' holds up her room card, e.g. *dining room*. The class responds *She's in the dining room*. The four pupils ask *What's she doing?* 'Nicola' mimes, e.g. drawing a picture. The class responds *She's drawing a picture*.

Pupils work in groups to prepare their performances for the class. Encourage them to be creative and funny.

● Extra activity 2: Mime story

Tell the following simple story to the class. Each time they hear the word *monster*, they pull a funny face; each time they hear the word *drawing*, they have to mime drawing; each time they hear the word *eating*, they have to mime eating; each time they hear *watching TV*, they lean forward and watch a fixed spot on the wall.

Story:

The old monster is a happy monster. He's in the kitchen. Guess what the monster's doing. Is he eating? No, he isn't. Is he watching TV? No, he isn't. Is he drawing? Yes, he is. The old monster's drawing a picture of a fish. Look! Oh, no! What's the monster doing? He's eating the picture of the fish. What a silly monster!

Page 82

● Extra activity 1: Pointing game

Play the game from Page 74 Extra activity 1, using the following words (in any order): *Face, fish, five, four, foot, feet, goat, girl, guitar, grandma, grandpa, grey, green, horse, helicopter, hand, happy, hair.*

● Extra activity 2: Tic tac toe

Pupils look at the pictures in Activity Book page 82 Activity 8 for one minute. Say *Stop. Close your books and put them in your bags.* Divide the class into two teams. Draw a 3 x 3 grid on the board. One team is X; the other O. Write numbers 1–9 in the squares. The first team, e.g. the X team, chooses a number in a square, e.g. 2. Ask question 2 below. They must answer it correctly. If they do, erase the 2 and draw a X. If they don't, then leave the 2 for another turn. Then the other team has a go. Repeat, with teams taking turns until one of the teams has a line of X or O or the grid is full.

Use the following (or your own) questions:

1. *Where's the crocodile?* (In the bathroom)
2. *What's the lion doing?* (Listening to music)
3. *What's the hippo doing?* (Reading)
4. *What's the tiger eating?* (A fish)
5. *Where's the tiger?* (In the kitchen)
6. *What's the crocodile doing?* (Having a bath)
7. *Is the lion sitting on a chair?* (No, a sofa)
8. *Is the crocodile happy?* (Yes, it is)
9. *Where's the hippo?* (In bed/In the bedroom)

Page 83

● Extra activity 1: Role play

Make groups of four. Pupils decide who is who from the story in Pupil's Book page 83 Activity 11. Play the story again (CD4, 33). They act out the story along with the CD.

● Extra activity 2: Room dictation [YLE]

Hand out Photocopiable 11 to pairs of pupils. They prepare the materials if they did not use them for page 79 Extra activity 2.

Do a dictation about the objects and the rooms in the house. Say, e.g. *This is my house. In the kitchen, I've got a jacket, a guitar and, oh, my pet bird. In the dining room, I've got ...*, etc. Pairs place the objects in the rooms. The pair(s) with the most correct objects in the correct rooms is/are the winners.

Unit 12

Page 84

● Extra activity 1: Guessing game

Display the eight foods (flashcards 91–96 and pictures of an orange and a fish) on the board. Write a number between 1 and 10 under each one. Demonstrate the game for the class. Stick a small piece of paper on the board and secretly write a number under it corresponding to one of the foods. Pupils take turns to guess, e.g. *Is it an orange? Is it some cake? Is it a banana?* Answer *No, it isn't* until they guess correctly and then say *Yes, it is.*

Pupils then play the game in pairs. Pupil A writes a number where Pupil B can't see it. Pupil B then tries to guess what the food is. Pupils swap roles. They repeat the game several times.

● Extra activity 2: Board slap

Play Board slap from page 8 Extra activity 1 using the six food flashcards (91–96).

Page 85

● Extra activity 1: Making groups

Note: You will need a large empty space, such as a gymnasium, for this game.

Hand each pupil a flashcard. (Choose the flashcards so that they form initial letter groups, e.g. c: *cake, car, crocodile*; b: *ball, blue, banana*.) Give them time to check with their friends what it is (if they can't remember). Demonstrate the game, e.g. point to a corner and say *All /c/ words here*. Pupils with an initial letter 'c' run to the corner. Repeat for other initial letters and other actions, e.g. *Sit down, jump up, stand up, freeze*. Pupils change cards. Continue with different instructions for the groups.

● Extra activity 2: Guessing game

Demonstrate the game for the pupils first. Say *I'm thinking, I'm thinking. Can you guess? It's yellow ... and you can eat it*. Pupils take turns to guess (banana). Do another example which is not so easy, e.g. *I'm thinking, I'm thinking. Can you guess? We've got lots of them in the classroom. They're young and ...* (pupils). Continue, revising adjectives, structures and vocabulary from the units. More confident pupils can take turns to give the clues.

Page 86

● Extra activity 1: Likes and dislikes

Hand out a set of Photocopiable cards from Unit 3 (toys) and Unit 8 (clothes) to each pair of pupils. They put them face up on the desk and review the words. Pupil A says, e.g. *I like dolls. I don't like computers*. Pupil B moves the doll card to a 'like' pile and the computer card to a 'don't like' pile. They continue until all the cards are in two piles. Then they spread out the cards again and swap roles.

● Extra activity 2: How many ... ?

Pupils work in groups of six. They look at all the group's sentences from Activity Book page 86 Activity 6 and count up the foods they dislike and like. Draw a simple 2 x 4 grid on the board, food words along the top, *like* and *dislike* at the side. Collect the information like this. Ask each group, e.g. *How many pupils in your group like fish? How many pupils in your group don't like fish?* Collate the information on the board. Repeat for the other foods.

Page 87

● Extra activity: Chain game

Demonstrate the game first for the class. Say *On my plate I've got two bananas*. Pupil 1 says, e.g. *On my plate I've got two bananas and some cake*. Pupil 2 says, e.g. *On my plate I've got two bananas, some cake and five apples*.

Pupils play in groups of six. They take turns to start the chain. The chain runs for six pupils. Pupils can't repeat the food in a chain.

Page 88

● Extra activity 1: Pictograms

Review with pupils the foods they like and dislike.

Pupils work individually. They write a sentence as in Pupil's Book page 88 Activity 10, drawing two pictures for their likes and two for their dislikes. Remind them they can also include animals, sports, clothes, etc.

Pupils display their pictograms for the class to read.

● Extra activity 2: Spelling game

Pupils work in pairs. They choose one object, draw a picture of it and write the letters in scrambled order on/in the pictures. Make this a revision activity by giving pairs different units in the book to work from. They colour their pictures and cut them out. Collect the pictures.

Put four pairs together to make groups of eight. Place four pictures face down on their tables (make sure you give groups new pictures, not the ones pairs did). Each pair needs a pencil and paper. Say *Ready, steady, go*. They turn over one picture. Each pair races to write the letters of the word in the correct order on their paper. The first pair to do it correctly wins a point. They repeat for the other three pictures, doing one at a time.

Monitor the groups to make sure there is no cheating.

Page 89

● Extra activity 1: Class food train

Each pupil writes and draws their favourite food on a large piece of paper, e.g. if a pupil likes chocolate and oranges, they write and draw *chocolate* on one piece of paper and *oranges* on the other.

You will need space to do this activity. Pupils line up behind you to make the food train. Start moving slowly like a train, hold up one picture and say the word twice. Repeat for the other picture. The pupil behind you then does the same, and on down the line. The train snakes around the room as pupils say their words. If you have a big class, you can have three or four trains snaking around the room at the same time.

● Extra activity 2: Spell it

Optional: *Primary Reading Box* 0.3, Spell it. You will need to teach or elicit the new words before the pupils play the game: *milk, water, bread, juice*.

Page 90

● Extra activity 1: Can you remember?

Hold up Pupil's Book page 90 and point to the painting by Giuseppe Arcimboldi. Write the following description on the board: *It's a man. His head is food. His hair is grapes. His face is an apple*. Read the description aloud. Say the first sentence and gesture that you want the pupils to repeat. Do the same with the rest of the sentences. Have pupils say the whole description in chorus several times. Now erase three key words from the description (e.g. *man, food, face*). Point to the beginning of the description and invite the class to say the whole thing, replacing the missing words from memory. Erase three more words (e.g. *head, grapes, apple*) and have pupils say the whole description again. Continue in this way, removing more and more words. See if the class can say the whole paragraph from memory. Ask volunteers to say the paragraph on their own. Give them lots of praise if they can do this.

● Extra activity 2: Picture dictation

Draw the outline of a face on the board (no features, no ears, no hair). Say *Copy*. Pupils draw the outline in their notebooks. Say *Listen and draw a face. It's my friend. Her name is Flora Food*. Read the following description line by line, pausing to give pupils time to draw each feature:

This is Fiona. Fiona Food. Her nose is a watermelon.

Her eyes are oranges.

Her mouth is a banana.

Her ears are fish.

Her hair is burgers.

Pupils compare their pictures in pairs or small groups.

Page 91

Extra activity 1: Activity mime game

Hand the toothbrushes, bars of soap and apples to six random pupils in the class. Play the music CD. Pupils pass the items to the pupil on their left. They keep passing them around until the music stops. When the music stops, pupils who are holding an object stand up and act either brushing their teeth (if they are holding a toothbrush), washing their hands (if they are holding a bar of soap) or washing an apple (if they are holding an apple). Ask the pupils who are acting in turn *What are you doing?* They reply, e.g. *I'm washing an apple*. Start the music again and repeat the game.

Extra activity 2: Clean or wash?

Write the words the *bathroom, your hands, your shoes, pears, grapes, your teeth, the kitchen, apples* on the board. Then draw two columns, one with the word *clean* at the top and one with the word *wash*. Say *Read the words. Clean or wash? Copy and write*. Pupils copy the table in their notebooks and work in pairs to put the words into the correct columns. Check answers with the class.

Key: clean – the bathroom, your shoes, your teeth, the kitchen; wash – your hands, pears, grapes, apples

Review Units 9–12

Page 92

● Extra activity 1: Word families

Play a game with the class. Select three or four flashcards from each of the following groups: colours, face, toys, pets, wild animals, food, funfair, school. Display them, picture side, on the board. Divide the class into groups of four. Tell groups to work quietly so the others don't hear. Call out, e.g. *Number 1. Pets*. Pupils in the groups write the name of a pet from the board on paper. Continue calling numbers and word groups. There will be eight in all.

Pupils swap their papers with another group. Check with the class by eliciting the flashcards for each word family and moving them into a group on the board.

The group(s) with the most correct answers is/are the winners.

Extra activity 2: Play a game

Play one of the games from Units 9–12 with the class.

Page 93

● Extra activity 1: Play a game

Play one of the games from the book with the class.

● Extra activity 2: Sing a song or do a chant

Sing one of the songs or do a chant from Units 9–12 with the class.

Name:

Listen and colour.

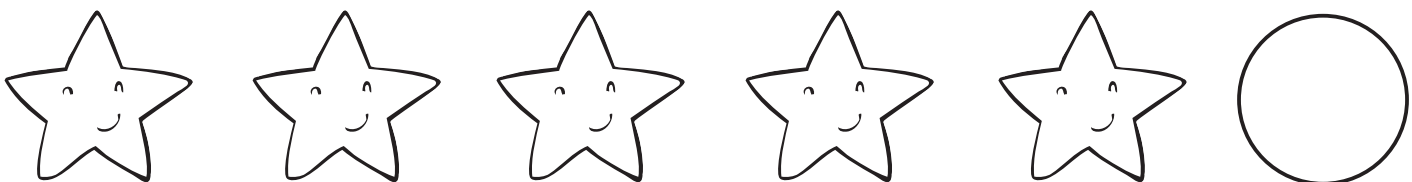

Name:

1 Give your monster a name.

My monster's name is

2 Colour the clothes. Colour the face.



3 Talk about your monster.

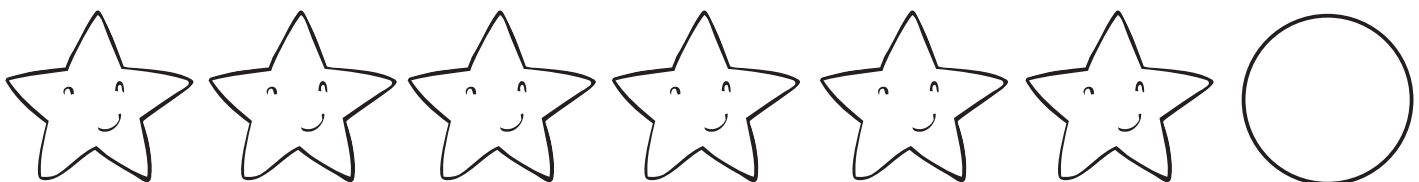

Evaluation 3

Reading and writing



Part 1. Look and read.

Yes or no?

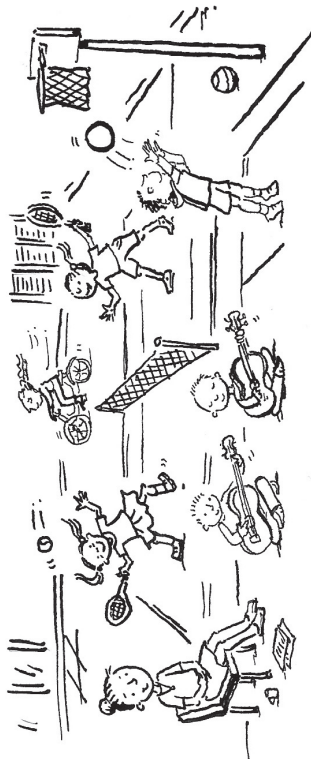

1 A boy is playing tennis.
.....

2 A girl is riding a bike.
.....

3 The boys are playing basketball.
.....

4 There is a teacher on a chair.
.....

5 The girls are playing the piano.
.....

Part 2. Look at the pictures.
Look at the letters. Write
the words.

6

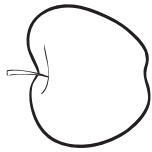

p e a l p
.....

7

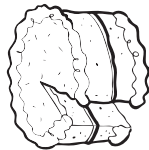

k e c a
.....

8

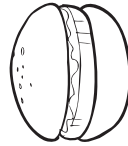

r u g r e b
.....

9



c l o c e t h o a
.....

10

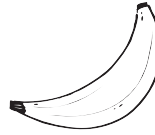

n a a a n b
.....

